

ERO/EPO/EHU

Air Handling Units

ERO HGN/EPO HGN/EHU HGN

Hygienic Air Handling Units

ERO AC/EPO AC/EHU AC

Packaged Type Heat Recovery Units With Heat Pump



Index

ERO/EPO/EHU

- Unit Components	2
- Technical Specification & Unit Dimensions	10
- Unit Configurations	13
- Control System	17

EPO HGN/EHU HGN

- Unit Components	22
- Hygienic Air Handling Units	24
- Round Around Coil (RAC) Systems	26
- Technical Specification & Unit Dimensions	27
- Unit Configurations	28
- Control System	31

ERO AC/EPO AC/EHU AC

- Unit Components	34
- Heat Recovery Units with Heat Pump	40
- Technical Specification & Unit Dimensions	41
- Unit Configurations	42
- Control System	45

Accessories

- Duct Type Sound Attenuator	48
- Recirculation Module	49
- Duct Type Electric Heaters	50
- Constant Flow Kit	50
- Humidifier	50
- Ventilation on Demand	51
- Pressure Gauge	51
- Communication	51

General Terms and Conditions of Sale	52
--------------------------------------	----



Exhaust and Supply Air Fans

The fans in air handling units are equipped with innovative Electronically Commutated EC motor technology. EC motors have higher efficiency and simple speed control. Fan blades have high aerodynamic efficient backward curved design. EC motors reduce the energy consumption and increase the energy efficiency of the unit. With EC Fans, maintenance costs are reduced as the fans are directly connected to the motors; the belt and pulley problems are eliminated.

Control System Plug&Play

Units are equipped with a microprocessor based control system to meet various design needs. Both electrically and electronically control hardware comes with the unit that's why the unit is "Plug and Play". Exchanger monitoring and speed control, filter monitoring, fan monitoring are standard. With the use of optional IAQ, CO2 sensor or constant flow kit, fans regulate automatically according to user demand. Room control panel is supplied where no BMS protocol is demanded. The panel is BMS compatible and can handle various communication protocols like Modbus, Bacnet and Lonworks. Control System is also capable of controlling heating/cooling capacity when units are used with heating/cooling coils.

Casing & Insulation

The unit's casing is made up of double skinned high corrosion resistive 200 gr/m² galvanize coated steel. 50 mm thickness and 70kg/m³ density of Rockwool insulation between the walls is used for thermal and sound insulation. Screw-adjustable feet are also available as an option under the base frame. The case of unit is painted by electrostatic powdered paint. The unit is constructed in sections to ease transportation, mounting and commissioning. Every section has its own basis and transport slots.

Rotary Heat Recovery

ERO air handling units have high efficient rotary heat recovery exchangers with Eurovent certification. The exchanger transfers sensible heat and moisture between supply and exhaust air. Thus, it is also possible to transfer latent heat. With the optimization of heat exchanger, temperature and humidity efficiency is increased, pressure drop is decreased. Optionally, condensation rotor can be used for sensible heat transfer and sorption rotor can be used for humidity transfer.

Exhaust and Supply Air Filters

ERO handling units have standard G class pre-filters for both exhaust and supply air streams. A choice of F class final filters can be preferred optionally. G class pre-filters are washable and secured in rigid frames made of galvanized steel. F class final filters are innovative compact filters with increased filtration surface area to reduce initial pressure drop over the filter and also reduce size of units. All the filters comply with EN 779 to meet the requirements of odor absorption and dust arrestment. Fouled filter information is indicated in the control panel by standard installed differential pressure switches however pressure transmitter is also available optionally to observe fouling. Filter sections are designed to ease filter service and changing.



Exhaust and Supply Air Fans

The fans in air handling units are equipped with innovative Electronically Commutated EC motor technology. EC motors have higher efficiency and simple speed control. Fan blades have high aerodynamic efficient backward curved design. EC motors reduce the energy consumption and increase the energy efficiency of the unit. With EC Fans, maintenance costs are reduced as the fans are directly connected to the motors; the belt and pulley problems are eliminated.

Control System Plug&Play

Units are equipped with a microprocessor based control system to meet various design needs. Both electrically and electronically control hardware comes with the unit that's why the unit is "Plug and Play". Exchanger monitoring and speed control, filter monitoring, fan monitoring are standard. With the use of optional IAQ, CO2 sensor or constant flow kit, fans regulate automatically according to user demand. Room control panel is supplied where no BMS protocol is demanded. The panel is BMS compatible and can handle various communication protocols like Modbus, Bacnet and Lonworks. Control System is also capable of controlling heating/cooling capacity when units are used with heating/cooling coils.

Casing & Insulation

The unit's casing is made up of double skinned high corrosion resistive 200 gr/m² galvanize coated steel. 50 mm thickness and 70kg/m³ density of Rockwool insulation between the walls is used for thermal and sound insulation. Screw-adjustable feet are also available as an option under the base frame. The case of unit is painted by electrostatic powdered paint. The unit is constructed in sections to ease transportation, mounting and commissioning. Every section has its own basis and transport slots.

Exhaust and Supply Air Filters

EPO handling units have standard G class pre-filters for both exhaust and supply air streams. A choice of F class final filters can be preferred optionally. G class pre-filters are washable and secured in rigid frames made of galvanized steel. F class final filters are innovative compact filters with increased filtration surface area to reduce initial pressure drop over the filter and also reduce size of units. All the filters comply with EN 779 to meet the requirements of odor absorption and dust arrestment. Fouled filter information is indicated in the control panel by standard installed differential pressure switches however pressure transmitter is also available optionally to observe fouling. Filter sections are designed to ease filter service and changing.

Heat Recovery Exchanger (Aluminum)

EPO air handling units have high efficient aluminum crossflow, plate heat recovery exchangers with Eurovent certification. Plate heat recovery exchangers have plates that are produced improved surface areas to provide high efficient and leakage free design. With the optimization of exchanger heat transfer is increased and pressure drop is decreased. It is recommended to use an electrical pre-heater to protect the exchanger when the outdoor air temperature is lower than -5°C.

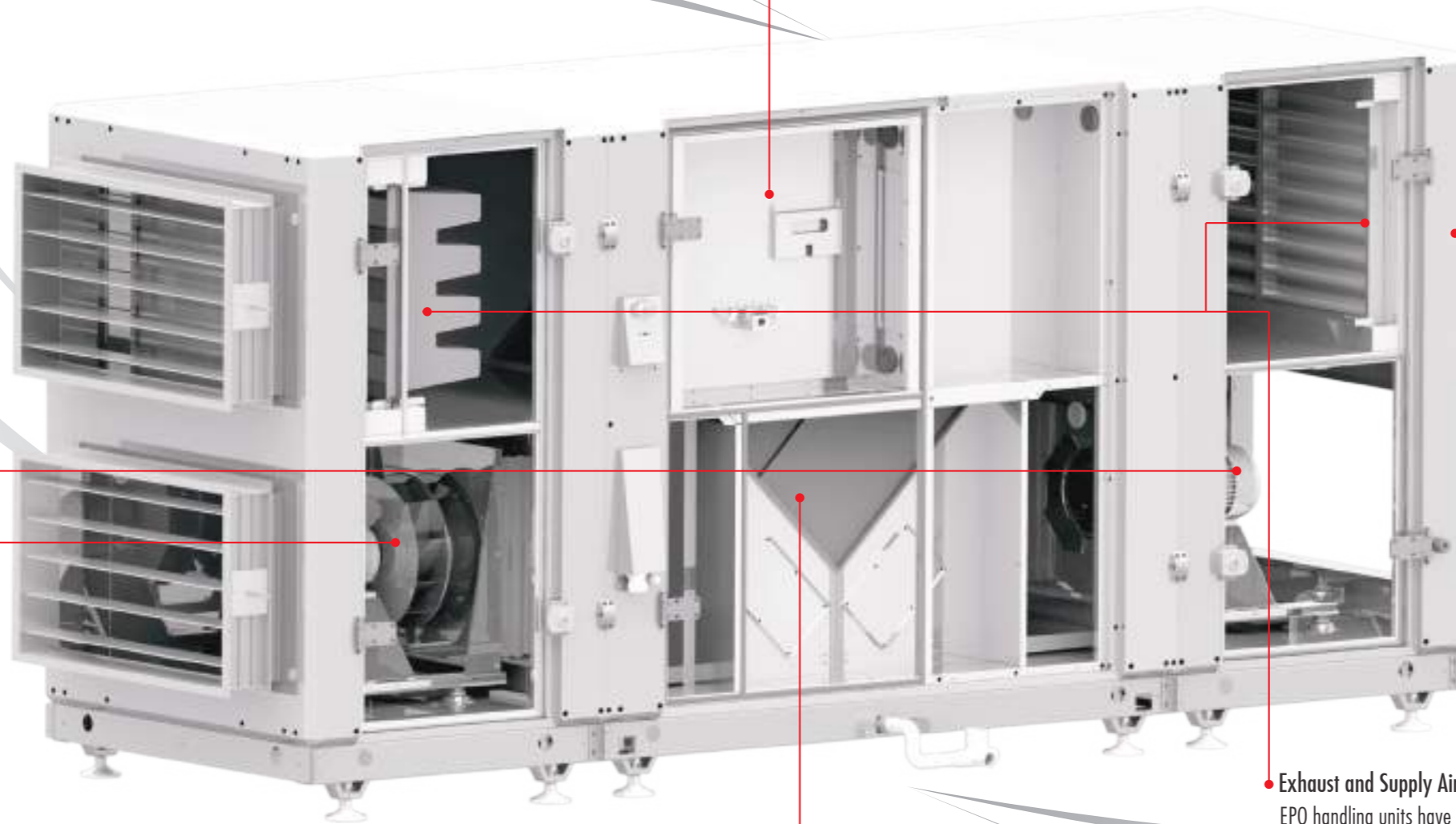

• **Exhaust and Supply Air Fans**

The fans in air handling units are equipped with innovative Electronically Commutated EC motor technology. EC motors have higher efficiency and simple speed control. Fan blades have high aerodynamic efficient backward curved design. EC motors reduce the energy consumption and increase the energy efficiency of the unit. With EC Fans, maintenance costs are reduced as the fans are directly connected to the motors; the belt and pulley problems are eliminated.

• **Control System**  Plug&Play

Units are equipped with a microprocessor based control system to meet various design needs. Both electrically and electronically control hardware comes with the unit that's why the unit is "Plug and Play". Filter monitoring, fan monitoring and DX system monitoring are standard. With the use of optional IAQ, CO2 sensor or constant flow kit, fans regulate automatically according to user demand. Room control panel is supplied where no BMS protocol is demanded. The panel is BMS compatible and can handle various communication protocols like Modbus, Bacnet and Lonworks. Control System is also capable of controlling heating/cooling capacity when units are used with heating/cooling coils.



• **Casing & Insulation**

The unit's casing is made up of double skinned high corrosion resistive 200 gr/m² galvanize coated steel. 50 mm thickness and 70kg/m³ density of Rockwool insulation between the walls is used for thermal and sound insulation. Screw-adjustable feet are also available as an option under the base frame. The case of unit is painted by electrostatic powdered paint. The unit is constructed in sections to ease transportation, mounting and commissioning. Every section has its own basis and transport slots.

• **Exhaust and Supply Air Filters**

EHU-D handling units have standard G class pre-filters for both exhaust and supply air streams. A choice of F class final filters can be preferred optionally. G class pre-filters are washable and secured in rigid frames made of galvanized steel. F class final filters are innovative compact filters with increased filtration surface area to reduce initial pressure drop over the filter and also reduce size of units. All the filters comply with EN 779 to meet the requirements of odor absorption and dust arrestment. Fouled filter information is indicated in the control panel by standard installed differential pressure switches however pressure transmitter is also available optionally to observe fouling. Filter sections are designed to ease filter service and changing.



Control System  Plug&Play

Units are equipped with a microprocessor based control system to meet various design needs. Both electrically and electronically control hardware comes with the unit that's why the unit is "Plug and Play". Filter monitoring, fan monitoring and DX system monitoring are standard. With the use of optional IAQ, CO2 sensor or constant flow kit, fans regulate automatically according to user demand. Room control panel is supplied where no BMS protocol is demanded. The panel is BMS compatible and can handle various communication protocols like Modbus, Bacnet and Lonworks. Control System is also capable of controlling heating/cooling capacity when units are used with heating/cooling coils.

Exhaust and Supply Air Fans

The fans in air handling units are equipped with innovative Electronically Commutated **EC motor** technology. EC motors have higher efficiency and simple speed control. Fan blades have high aerodynamic efficient backward curved design. EC motors reduce the energy consumption and increase the energy efficiency of the unit. With EC Fans, maintenance costs are reduced as the fans are directly connected to the motors; the belt and pulley problems are eliminated.



Exhaust and Supply Air Filters

EHU-S handling units have standard G class pre-filters for both exhaust and supply air streams. A choice of F class final filters can be preferred optionally. G class pre-filters are washable and secured in rigid frames made of galvanized steel. F class final filters are innovative compact filters with increased filtration surface area to reduce initial pressure drop over the filter and also reduce size of units. All the filters comply with EN 779 to meet the requirements of odor absorption and dust arrestment. Fouled filter information is indicated in the control panel by standard installed differential pressure switches however pressure transmitter is also available optionally to observe fouling. Filter sections are designed to ease filter service and changing.

Casing & Insulation

The unit's casing is made up of double skinned high corrosion resistive 200 gr/m² galvanize coated steel. 50 mm thickness and 70kg/m³ density of Rockwool insulation between the walls is used for thermal and sound insulation. Screw-adjustable feet are also available as an option under the base frame. The case of unit is painted by electrostatic powdered paint. The unit is constructed in sections to ease transportation, mounting and commissioning. Every section has its own basis and transport slots.



■ ERO / EPO Series

		ERO / EPO										
		010	015	030	055	070	090	125	175	225	300	400
Maximum Air Flow	m ³ /h	1000	1500	3000	5500	6800	8500	15300	18450	25900	30000	40000
Nominal Voltage	V/Hz/f	400/ 50 /3~										

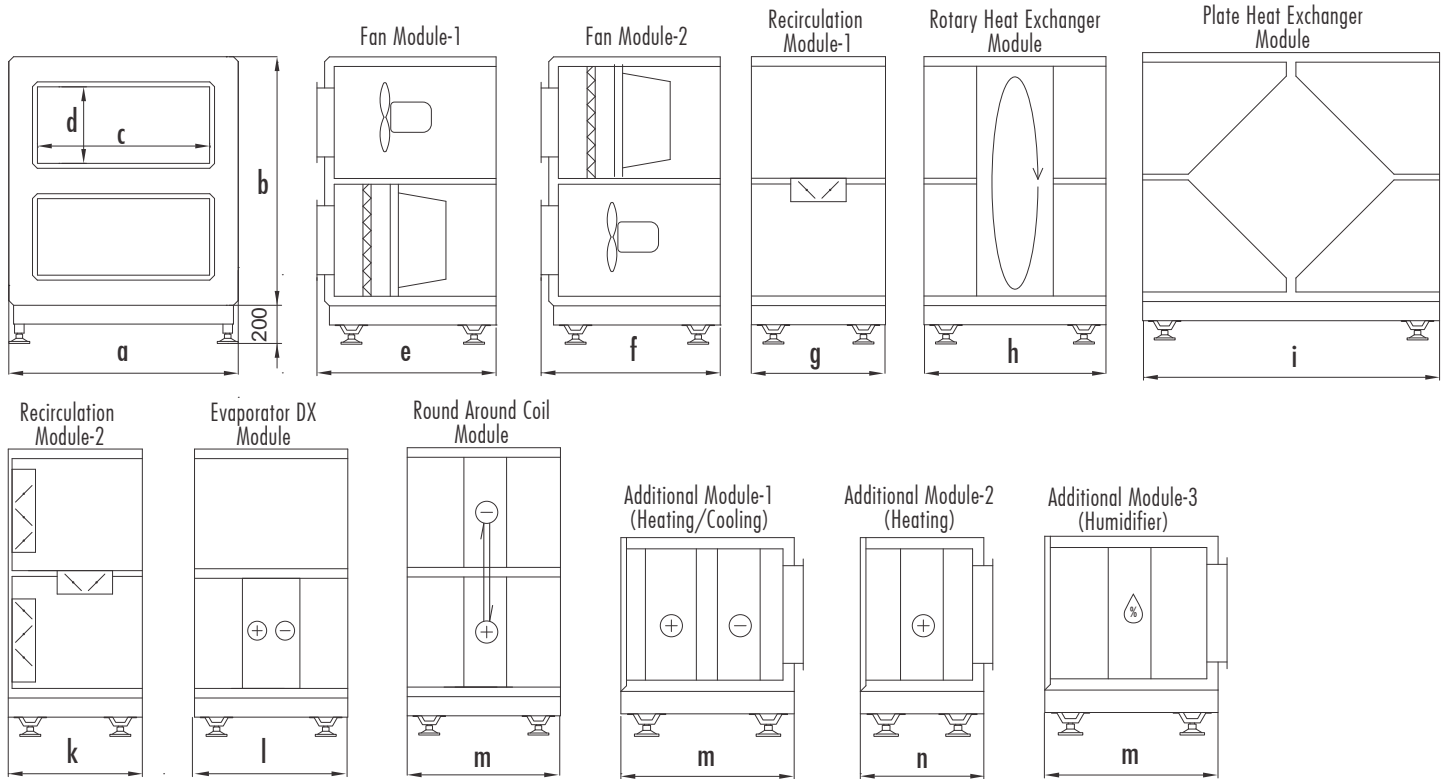

Type	a	b	cx d	e	f	g	h	i	k	l	m	n
ERO/EPO 010	850	900	550x200	955	955	700	950	1550	700	800	825	600
ERO/EPO 015	950	950	650x200	955	955	700	950	15550	700	800	825	600
ERO/EPO 030	1200	1300	900x400	1115	1115	700	950	1550	700	800	825	600
ERO/EPO 055	1200	1580	900x500	1115	1115	700	950	1880	700	800	825	600
ERO/EPO 070	1450	1580	1150x500	1115	1115	700	950	1880	700	800	825	600
ERO/EPO 090	1700	1800	1400x600	1115	1115	700	950	1880	700	800	825	600
ERO/EPO 125	1950	2200	1650x800	1115	1115	700	950	2100	700	800	825	600
ERO/EPO 175	2200	2450	1900x900	1115	1115	700	950	2300	700	800	825	600
ERO/EPO 225	2450	2650	2150x1000	1215	1215	700	950	2435	700	850	825	600
ERO/EPO 300	3050	2650	2750x900	1215	1215	700	950	2775	700	850	825	600
ERO/EPO 400	3500	2900	3200x1000	1215	1215	700	950	2400	700	850	825	600

Service Space

*All measurement values are mm.

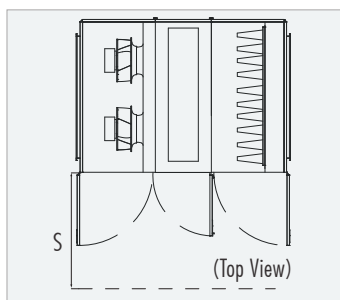

	ERO 10/15 EPO 10/15	ERO 30/55 EPO 30/55	ERO 70/90 EPO 70/90	ERO 125/175 EPO 125/175	ERO 225/300/400 EPO 225/300/400
S	1000	1200	1500	2000	2500

*All measurement values are mm.

Technical Specifications and Unit Dimensions

■ EHU-D Series

		EHU-D 010	EHU-D 015	EHU-D 030	EHU-D 055	EHU-D 070	EHU-D 090	EHU-D 125	EHU-D 175	EHU-D 225	EHU-D 300	EHU-D 400
Maximum Air Flow	m ³ /h	1000	1500	3000	5500	6800	8500	15300	18450	25900	30000	40000
Nominal Voltage	V/Hz/f	400/ 50 /3~										

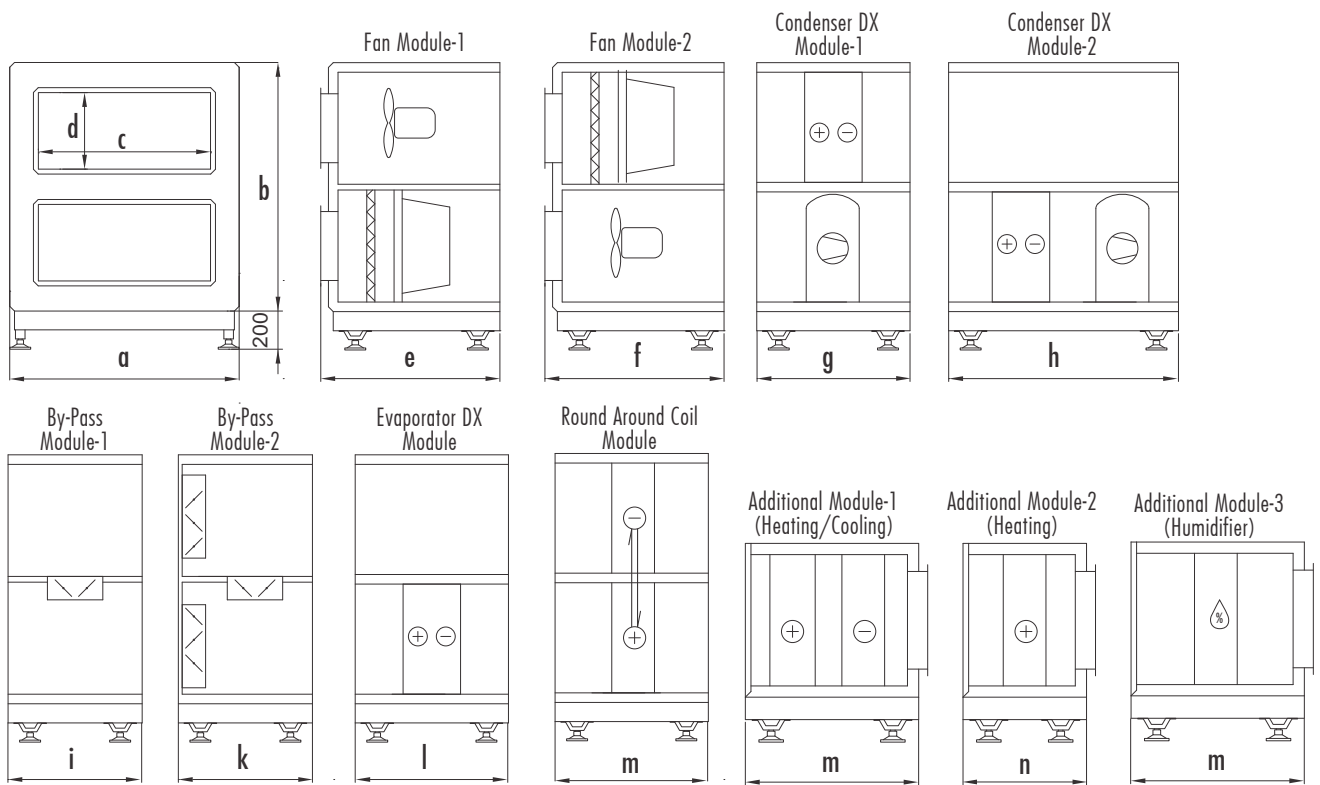

Type	a	b	cx d	e	f	g	h	i	k	l	m	n
EHU-D 010	850	900	550x200	955	955	800	1200	700	700	800	825	600
EHU-D 015	950	950	650x200	955	955	800	1200	700	700	800	825	600
EHU-D 030	1200	1300	900x400	1115	1115	800	1200	700	700	800	825	600
EHU-D 055	1200	1580	900x500	1115	1115	800	1200	700	700	800	825	600
EHU-D 070	1450	1580	1150x500	1115	1115	800	1200	700	700	800	825	600
EHU-D 090	1700	1800	1400x600	1115	1115	800	1200	700	700	800	825	600
EHU-D 125	1950	2200	1650x800	1115	1115	800	1200	700	700	800	825	600
EHU-D 175	2200	2450	1900x900	1115	1115	800	1260	700	700	800	825	600
EHU-D 225	2450	2650	2150x1000	1215	1215	1000	1260	700	700	850	825	600
EHU-D 300	3050	2650	2750x900	1215	1215	1000	1830	700	700	850	825	600
EHU-D 400	3500	2900	3200x1000	1215	1215	1000	1830	700	700	850	825	600

*All measurement values are mm.

Service Space

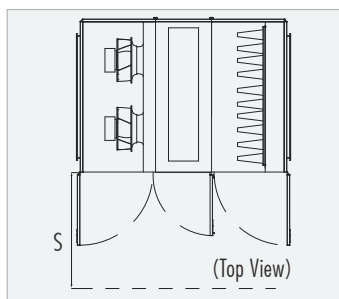

	EHU-D 10/15	EHU-D 30/55	EHU-D 70/90	EHU-D 125/175	EHU-D 225/300/400
S	1000	1200	1500	2000	2500

*All measurement values are mm.

Technical Specifications and Unit Dimensions

EHU-S Series

		EHU-S 010	EHU-S 015	EHU-S 030	EHU-S 055	EHU-S 070	EHU-S 090	EHU-S 125	EHU-S 175	EHU-S 225	EHU-S 300	EHU-S 400
Maximum Air Flow	m ³ /h	1000	1500	3000	5500	6800	8500	15300	18450	25900	30000	40000
Nominal Voltage	V/Hz/f	400/ 50 /3~										

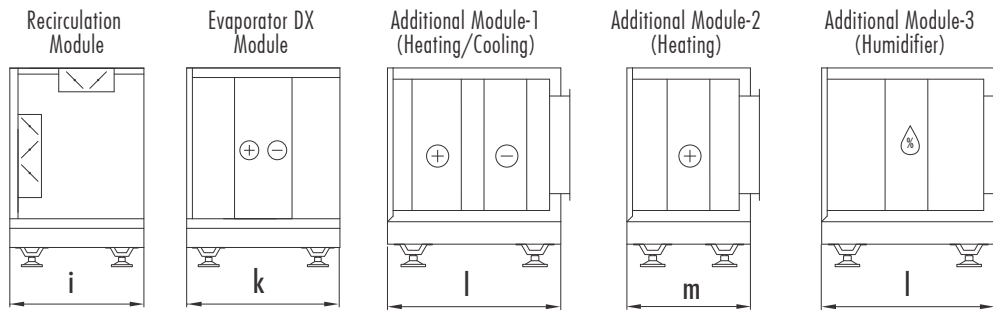
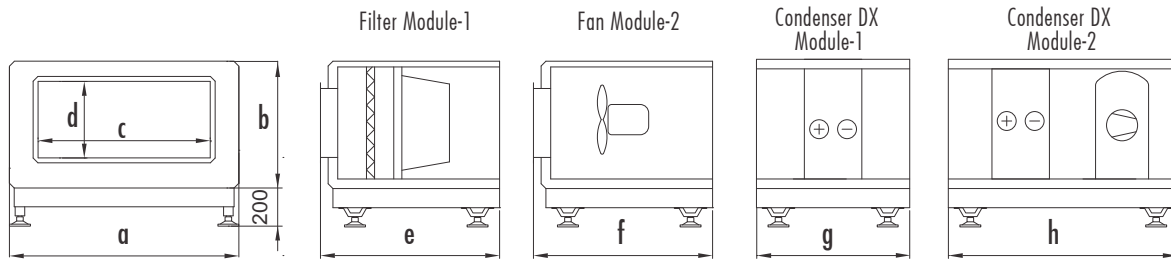

Type	a	b	cx d	e	f	g	h	i	k	l	m
EHU-S 010	850	485	550x200	955	955	800	1200	700	800	825	600
EHU-S 015	950	510	650x200	955	955	800	1200	700	800	825	600
EHU-S 030	1200	685	900x400	1115	1115	800	1200	700	800	825	600
EHU-S 055	1200	825	900x500	1115	1115	800	1200	700	800	825	600
EHU-S 070	1450	825	1150x500	1115	1115	800	1200	700	800	825	600
EHU-S 090	1700	925	1400x600	1115	1115	800	1200	700	800	825	600
EHU-S 125	1950	1125	1650x800	1115	1115	800	1200	700	800	825	600
EHU-S 175	2200	1250	1900x900	1115	1115	800	1260	700	800	825	600
EHU-S 225	2450	1350	2150x1000	1215	1215	1000	1260	700	850	825	600
EHU-S 300	3050	1350	2750x900	1215	1215	1000	1830	700	850	825	600
EHU-S 400	3500	1575	3200x1000	1215	1215	1000	1830	700	850	825	600

*All measurement values are mm.

Service Space

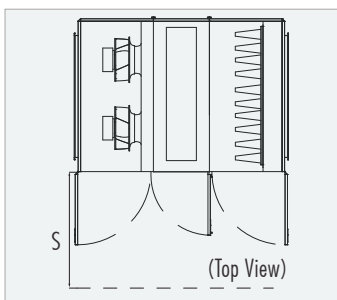

	EHU-S 10/15	EHU-S 30/55	EHU-S 70/90	EHU-S 125/175	EHU-S 225/300/400
S	1000	1200	1500	2000	2500

*All measurement values are mm.

■ ERO Series

100% Fresh Air

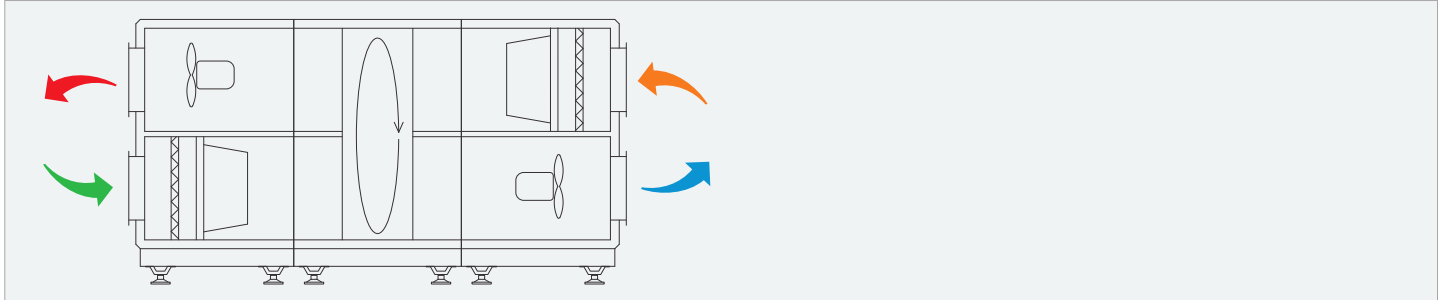

100% Fresh Air - Heating + Cooling Coil

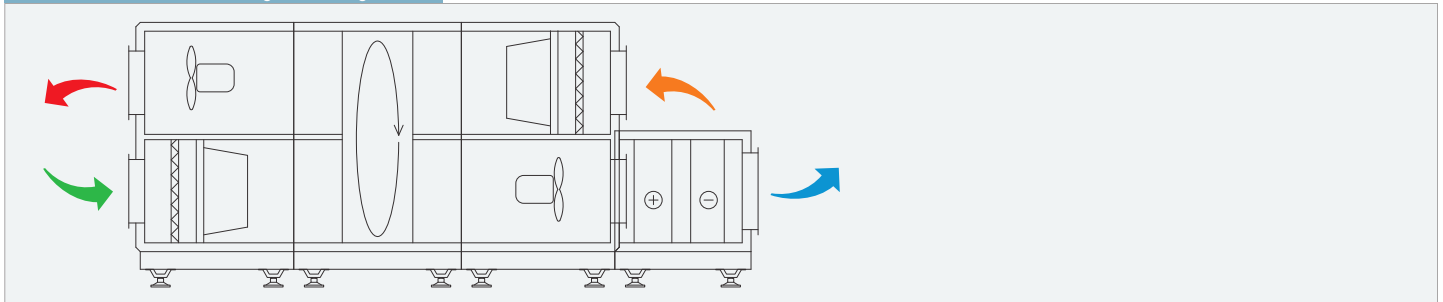

Recirculation Damper - Heating + Cooling Coil

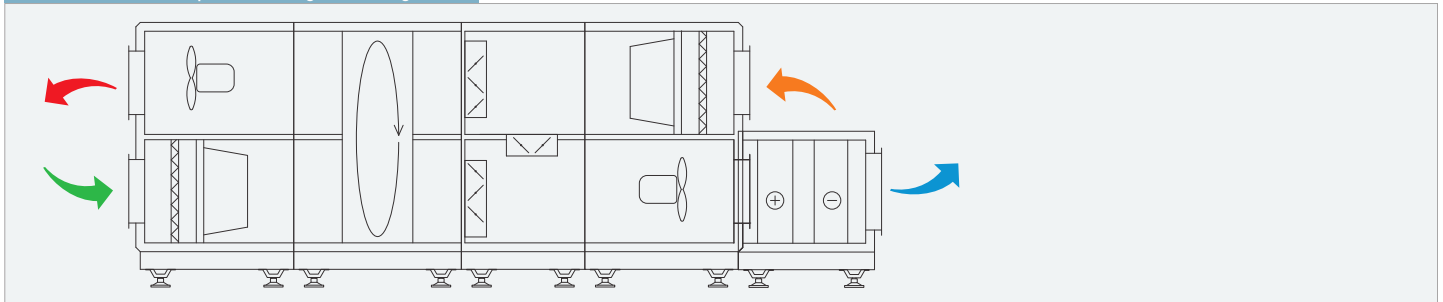

 Outdoor Air
  Supply Air
  Return Air
  Exhaust

Note: Configuration options are not limited with the examples given above, more configuration options are available according to demand.

EPO Series

100% Fresh Air

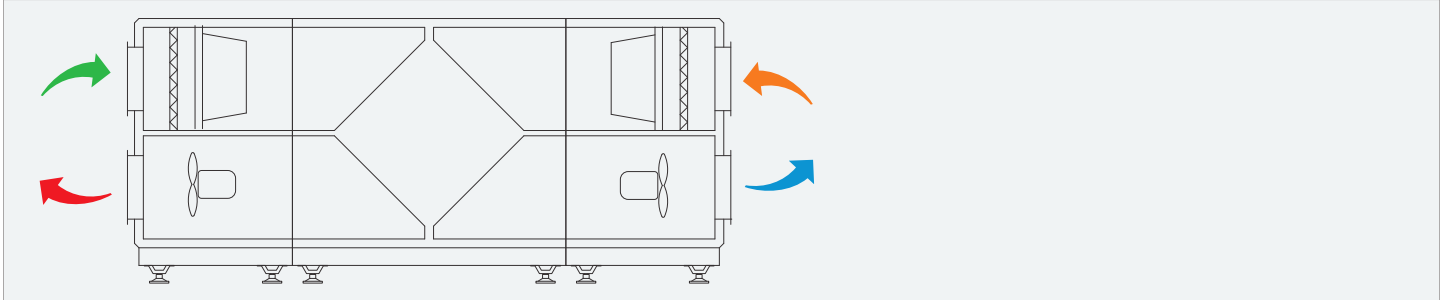

100% Fresh Air - Heating + Cooling Coil

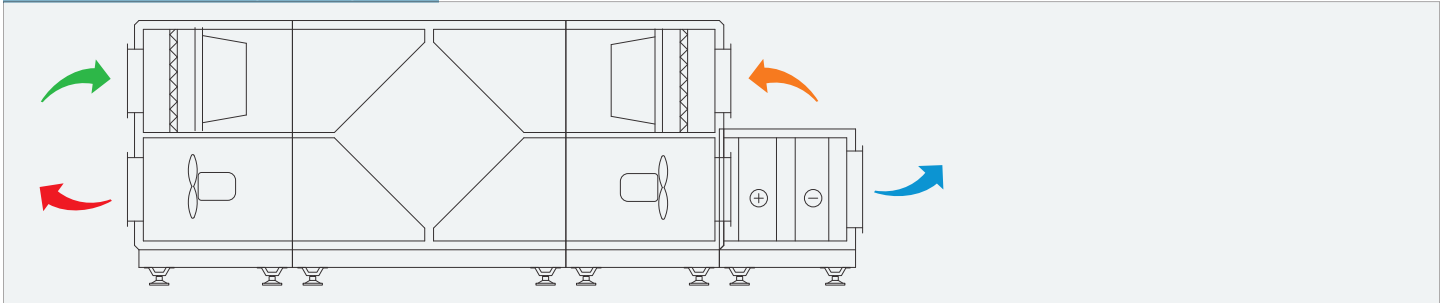

Recirculation Damper - Heating + Cooling Coil

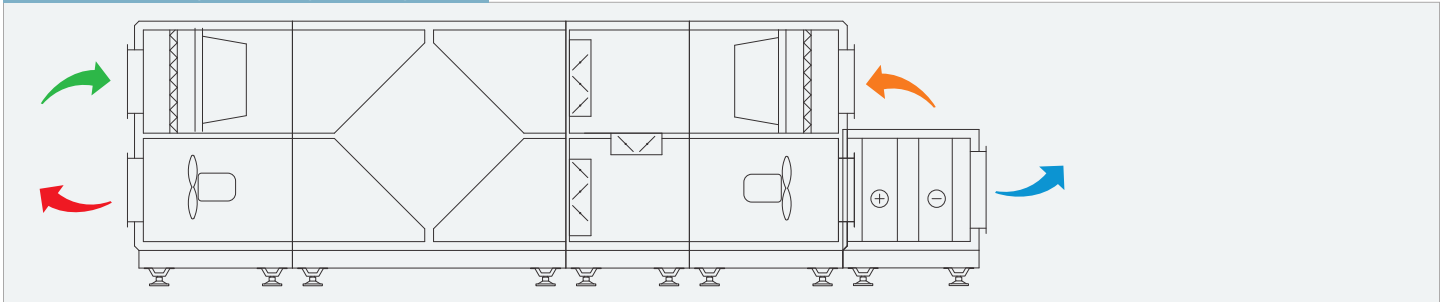

 Outdoor Air
  Supply Air
  Return Air
  Exhaust

Note: Configuration options are not limited with the examples given above, more configuration options are available according to demand.

■ EHU-D Series

100% Fresh Air

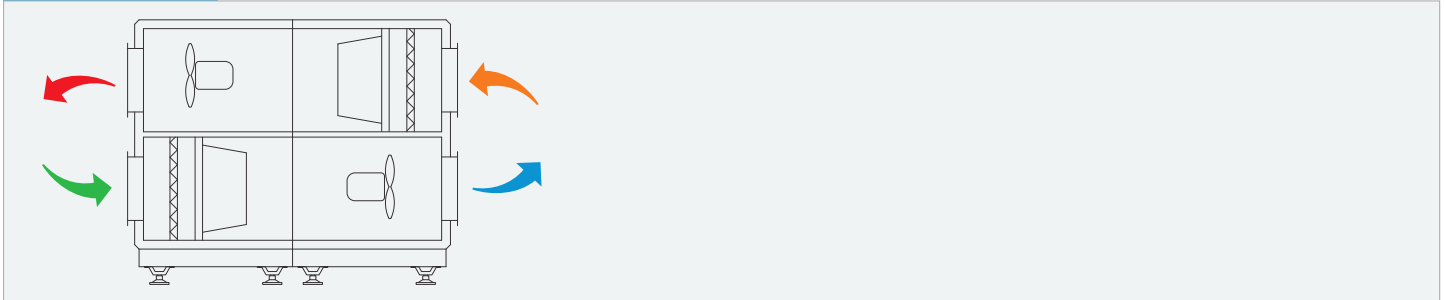

100% Fresh Air - Heating + Cooling Coil

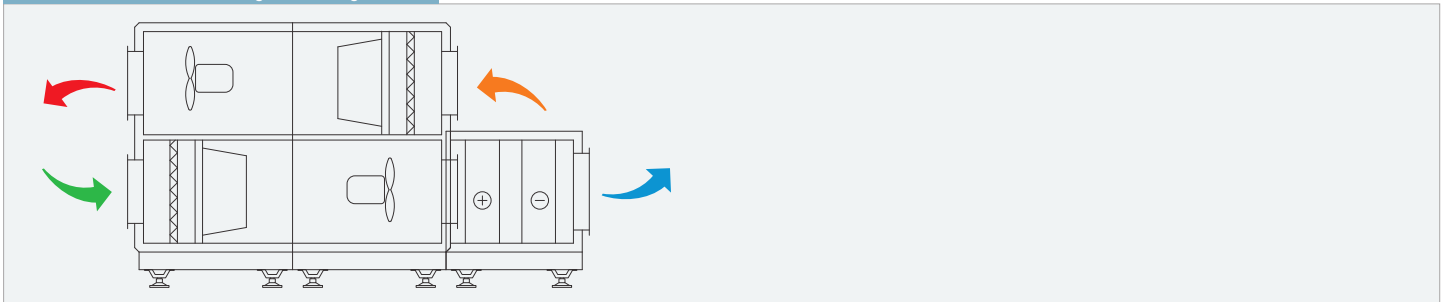

Recirculation Damper - Heating + Cooling Coil

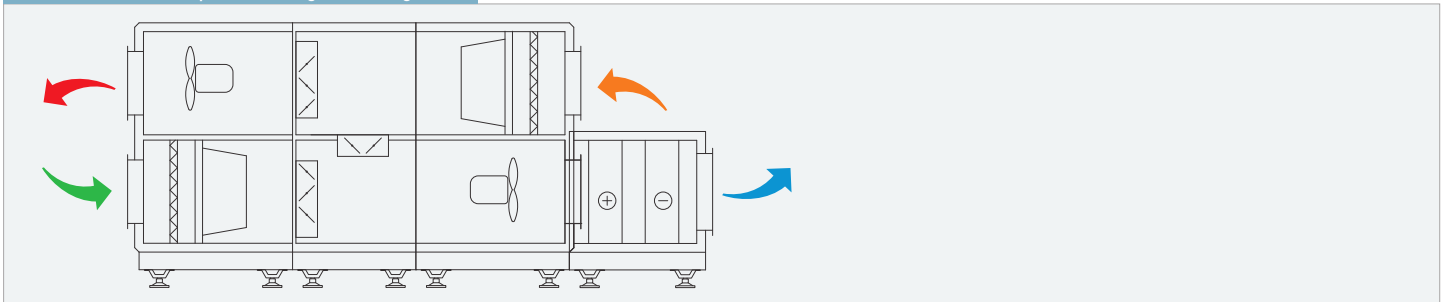

 Outdoor Air
  Supply Air
  Return Air
  Exhaust

Note: Configuration options are not limited with the examples given above, more configuration options are available according to demand.

■ EHU-S Series

100% Fresh Air

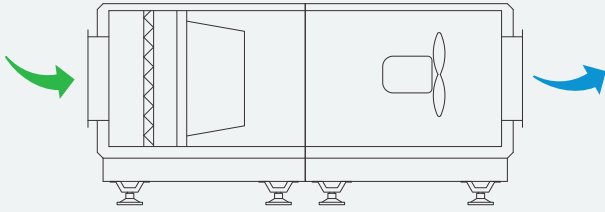

100% Fresh Air - Heating + Cooling Coil

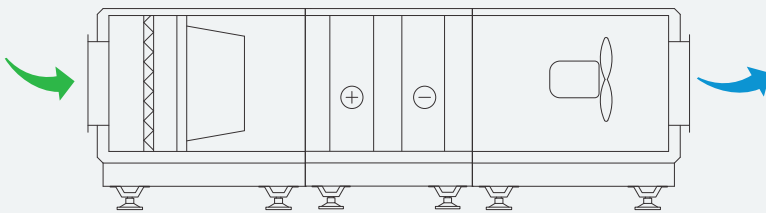

Mixing Damper - Heating + Cooling Coil

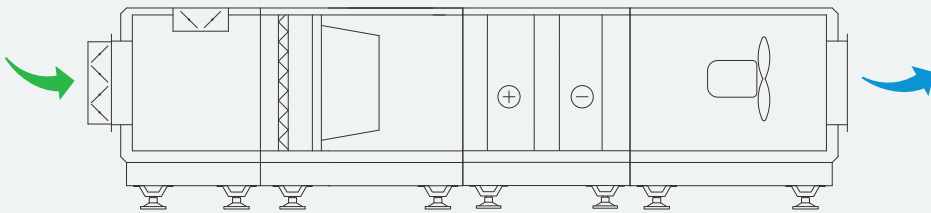



 Outdoor Air  Supply Air

Note: Configuration options are not limited with the examples given above, more configuration options are available according to demand.

■ ERO Series

Automation Options		Control Cards		
Standard	Optional	Standard		Alternative
		Type 1	Type 2	
OA Temperature Sensor		☑	☑	☑
RA Temperature Sensor		☑	☑	☑
SA Temperature Sensor		☑	☑	☑
SA Fan Control		☑	☑	☑
RA Fan Control		☑	☑	☑
On/Off Damper Control		☑	☑	☑
On/Off Rotor Control		☑	☑	☑
Filter Contamination Info (Time)		☑	☑	☑
Modbus RTU		☑	☑	☑
Web Browser (TCP/IP)		☒	☑	☑
	Proportional Rotor Control	☑	☑	☑
	Proportional Damper Control	☑	☑	☑
	Airflow Control	⊖	☑	☑
	Humidity Control		☑	☑
	CO2 Control		☑	☑
	On/Off Heating Coil	☑	☑	☑
	Proportional Heating Coil	☑	☑	☑
	On/Off Cooling Coil	☑	☑	☑
	Proportional Cooling Coil	☑	☑	☑
	Electrical Pre-Heater	☑	☑	☑
	Electrical After-Heater	☑	☑	☑
	BacNET MSTP	☑	☑	☑
	Weekly Timer	☑	☑	☑
	Filter Contamination Info (DPS)	☑	☑	☑



⊖ Only one of them of defined functions is selectable for this control card.

Control Panel		Control Cards		
Panel Type	Panel Descriptions	Standard		Alternative
		Type 1	Type 2	
	Standard-1.1 Hand Panel 1: Wall-mounted type, IP 65 protection class for only front side of panel, Max:50 m communication ability Hand Panel 2: Magnet type, IP 65 protection class for whole panel, Max:50 m communication ability	☑	☑	☒
		Standard-1.2 Magnet type, IP 31 protection class, Max:700 m communication ability	☑	☑
	Alternative Wall-mounted type hand panel, IP 30 protection class, Max:100 m communication ability	☒	☒	☑

EPO Series

Automation Options		Control Cards		
Standard	Optional	Standard		Alternative
		Type 1	Type 2	
OA Temperature Sensor		☑	☑	☑
RA Temperature Sensor		☑	☑	☑
SA Temperature Sensor		☑	☑	☑
SA Fan Control		☑	☑	☑
RA Fan Control		☑	☑	☑
On/Off Damper Control		☑	☑	☑
On/Off By-Pass Damper Control		☑	☑	☑
Filter Contamination Info (Time)		☑	☑	☑
Modbus RTU		☑	☑	☑
Web Browser (TCP/IP)		☒	☑	☑
	Proportional Damper Control	☑	☑	☑
	Proportional By-Pass Damper Control	☑	☑	☑
	On/Off Mixing Damper Control	☑	☑	☑
	Proportional Mixing Damper Control	☑	☑	☑
	Airflow Control		☑	☑
	Humidity Control	⊖	☑	☑
	CO2 Control		☑	☑
	On/Off Heating Coil	☑	☑	☑
	Proportional Heating Coil	☑	☑	☑
	On/Off Cooling Coil	☑	☑	☑
	Proportional Cooling Coil	☑	☑	☑
	Electrical Pre-Heater	☑	☑	☑
	Electrical After-Heater	☑	☑	☑
	BacNET MSTP	☑	☑	☑
	Weekly Timer	☑	☑	☑
	Filter Contamination Info (DPS)	☑	☑	☑



⊖ Only one of them the defined functions is selectable for this control card.

Control Panel		Control Cards		
Panel Type	Panel Descriptions	Standard		Alternative
		Type 1	Type 2	
	Standard-1.1 Hand Panel 1: Wall-mounted type, IP 65 protection class for only front side of panel, Max:50 m communication ability Hand Panel 2: Magnet type, IP 65 protection class for whole panel, Max:50 m communication ability	☑	☑	☒
	Standard-1.2 Magnet type, IP 31 protection class, Max:700 m communication ability	☑	☑	☒
	Alternative Wall-mounted type hand panel, IP 30 protection class, Max:100 m communication ability	☒	☒	☑

■ EHU-D Series

Automation Options		Control Cards		
Standard	Optional	Standard		Alternative
		Type 1	Type 2	
OA Temperature Sensor		☑	☑	☑
RA Temperature Sensor		☑	☑	☑
SA Temperature Sensor		☑	☑	☑
SA Fan Control		☑	☑	☑
RA Fan Control		☑	☑	☑
Proportional Damper Control		☑	☑	☑
Filter Contamination Info (Time)		☑	☑	☑
Modbus RTU		☑	☑	☑
Web Browser (TCP/IP)		⊗	☑	☑
	On/Off Damper Control	☑	☑	☑
	Airflow Control		☑	☑
	Humidity Control	⊖	☑	☑
	CO2 Control		☑	☑
	On/Off Heating Coil	☑	☑	☑
	Proportional Heating Coil	☑	☑	☑
	On/Off Cooling Coil	☑	☑	☑
	Proportional Cooling Coil	☑	☑	☑
	Electrical Pre-Heater	☑	☑	☑
	Electrical After-Heater	☑	☑	☑
	BacNET MSTP	☑	☑	☑
	Weekly Timer	☑	☑	☑
	Filter Contamination Info (DPS)	☑	☑	☑



⊖ Only one of them the defined functions is selectable for this control card.

Control Panel		Control Cards		
Panel Type	Panel Descriptions	Standard		Alternative
		Type 1	Type 2	
	Standard-1.1 Hand Panel 1: Wall-mounted type, IP 65 protection class for only front side of panel, Max:50 m communication ability Hand Panel 2: Magnet type, IP 65 protection class for whole panel, Max:50 m communication ability	☑	☑	⊗
		Standard-1.2 Magnet type, IP 31 protection class, Max:700 m communication ability	☑	☑
	Alternative Wall-mounted type hand panel, IP 30 protection class, Max:100 m communication ability	⊗	⊗	☑

EHU-S Series

Automation Options		Control Cards		
Standard	Optional	Standard		Alternative
		Type 1	Type 2	
OA Temperature Sensor		☑	☑	☑
SA Fan Control		☑	☑	☑
On/Off Damper Control		☑	☑	☑
SA Temperature Sensor		☑	☑	☑
Filter Contamination Info (Time)		☑	☑	☑
Modbus RTU		☑	☑	☑
Web Browser (TCP/IP)		⊗	☑	☑
	Proportional Damper Control	☑	☑	☑
	Airflow Control		☑	☑
	Humidity Control	⊖	☑	☑
	CO2 Control		☑	☑
	On/Off Heating Coil	☑	☑	☑
	Proportional Heating Coil	☑	☑	☑
	On/Off Cooling Coil	☑	☑	☑
	Proportional Cooling Coil	☑	☑	☑
	Electrical Pre-Heater	☑	☑	☑
	Electrical After-Heater	☑	☑	☑
	BacNET MSTP	☑	☑	☑
	Weekly Timer	☑	☑	☑
	Filter Contamination Info (DPS)	☑	☑	☑

⊖ Only one of them the defined functions is selectable for this control card.

Control Panel		Control Cards		
Panel Type	Panel Descriptions	Standard		Alternative
		Type 1	Type 2	
	Standard-1.1 Hand Panel 1: Wall-mounted type, IP 65 protection class for only front side of panel, Max:50 m communication ability Hand Panel 2: Magnet type, IP 65 protection class for whole panel, Max:50 m communication ability	☑	☑	⊗
		Standard-1.2 Magnet type, IP 31 protection class, Max:700 m communication ability	☑	☑
	Alternative Wall-mounted type hand panel, IP 30 protection class, Max:100 m communication ability	⊗	⊗	☑

The unit works at high efficiency thanks to proper design and the use of proper components as well as realization of properly installed control and automation systems.

Eneko designs are all-in-one solutions consisting MCC+DCC panels, control panel and relevant control systems based on customer requirements, project requirements and maximum efficiency resulting in reduced installation and operating costs.

Our units provide user monitoring and allows user inputs with user friendly control panel so that they can work as standalone devices even they are not connected to building automation.

Automation modules are used ModBus / Bacnet / Lonworks communication protocols as standard.

■ Automation system

- Frequency control in AC fans and flow control in EC fans, (working with constant or variable flow)
- Gradual fan speed control,
- Indoor air quality / airflow control based on CO₂ level or fresh air ratio control,
- Rotor speed control (depending on temperature or enthalpy)
- Damper control (on-off or proportional)
- By-pass damper control
- Hot water heater valve control (on-off or proportional)
- Cold water cooler valve control (on-off or proportional)
- Freezing control,
- Humidity control,
- Integrated DX module control (compressor running, compressor circuit control, gas pressure monitoring, dynamic defrost etc.),
- Electrical heating gradual control,
- Fire scenario compatible running,
- Automatic season selection,
- Free cooling running,
- Time programming,

Automation system is able to control those software applications listed above. Also; filter contamination and failure information can be taken from both the control panel and the building automation system. The working values can be monitored.

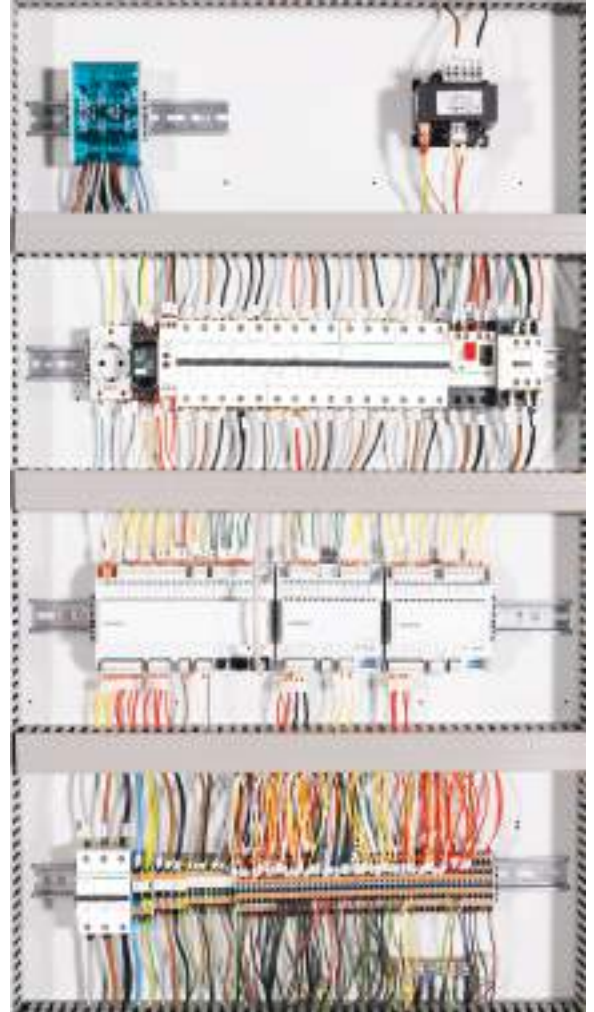

Exhaust and Supply Air Fans

The fans in hygienic air handling units are equipped with innovative Electronically Commutated **EC motor** technology. EC motors have higher efficiency and simple speed control. Fan blades have high aerodynamic efficient backward curved design. EC motors reduce the energy consumption and increase the energy efficiency of the unit. With EC Fans, maintenance costs are reduced as the fans are directly connected to the motors; the belt and pulley problems are eliminated.

Exhaust and Supply Air Filters

M and F class filters are compact depend on selection of the hygienic classroom. All filters are washable. Also, Filters are innovative compact filters with increased filtration surface area to reduce size of units. All the filters comply with EN 779 to meet the requirements of odor absorption and dust arrestment. Fouled filter information is indicated in the control panel by standard installed differential pressure switches however pressure transmitter is also available optionally to observe fouling. Filter sections are designed to ease filter service and changing.

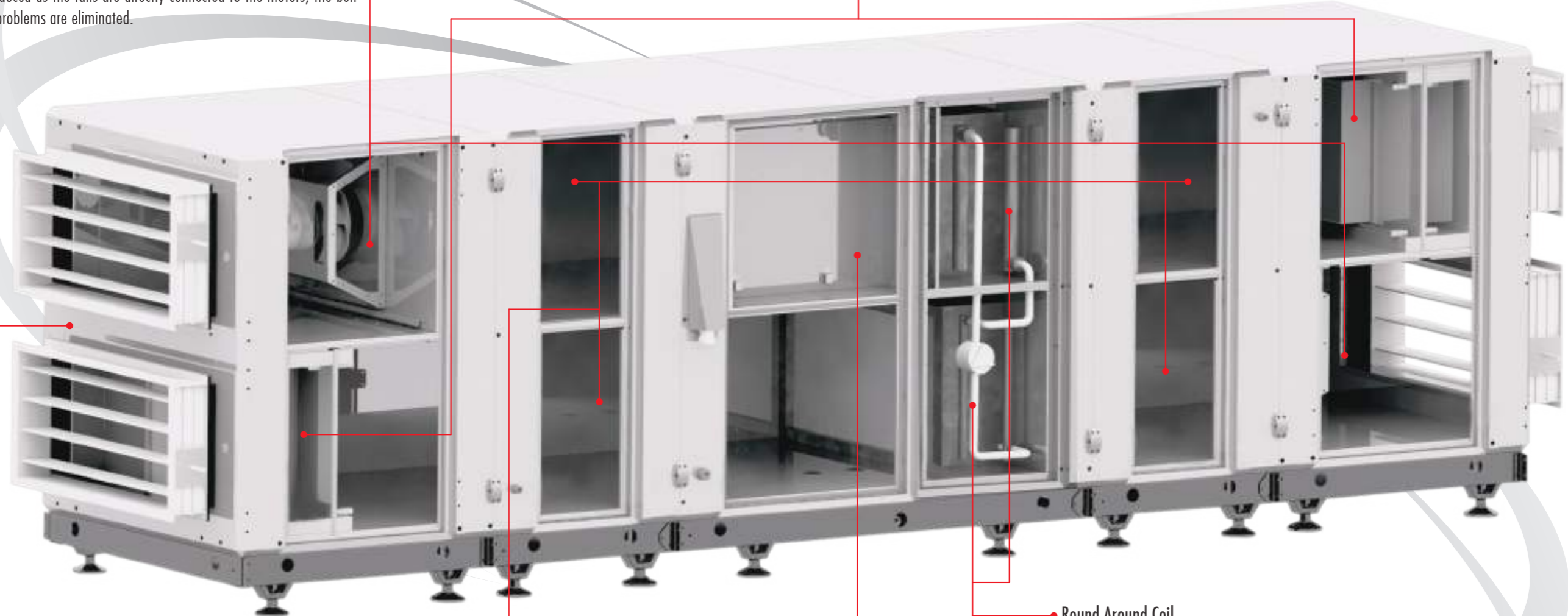

Service Cells

Gaps are given according to DIN 1946-4 and VDI6022 standards for servicing.

Round Around Coil

Copper tube - aluminum fin type and high efficiency coils are used. Round Around coil is a regenerative heat recovery system which completely separates supply and exhaust line. In the system, two lines are connected to each other by a hydraulic circuit. Capacity setting is done by circulation pump. Drop eliminator and drain pan are used for the coil located at return air.

Casing & Insulation

The unit's casing is made up of double skinned high corrosion resistive 200 gr/m² galvanize coated steel. 50 mm thickness and 70kg/m³ density of Rockwool insulation between the walls is used for thermal and sound insulation. Screw-adjustable feet are also available as an option under the base frame. The case of unit is painted by electrostatic powdered paint. The unit is constructed in sections to ease transportation, mounting and commissioning. Every section has its own basis and transport slots.

Control System  Plug & Play

Units are equipped with a microprocessor based control system to meet various design needs. Both electrically and electronically control hardware comes with the unit that's why the unit is "Plug and Play". Exchanger monitoring and speed control, filter monitoring, fan monitoring are standard. With the use of optional IAQ, CO2 sensor or constant flow kit, fans regulate automatically according to user demand. Room control panel is supplied where no BMS protocol is demanded. The panel is BMS compatible and can handle various communication protocols like Modbus, Bacnet and Lonworks. Control System is also capable of controlling heating/cooling capacity when units are used with heating/cooling coils.

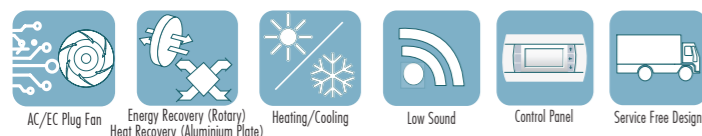

Hygienic systems are quite different from comfort applications in terms of system design and unit specifications. It is only possible to know which units can be suitable for selected system type by knowing usage area and purpose. It is possible to make a hygienic air conditioning system that works smoothly as a result of well-designed system.

Hygienic type air handling units has been developed to meet requirements for hygienic areas such as hospitals, operation rooms, pharmaceutical industry, clean rooms, food and storage facilities. Additionally, hygienic type air handling units can be used for indoor environments such as removing bacteria from infectious diseases unit and removing gases used during anesthesia from sterile medium etc. All components used in the unit have an effect on the quality and hygiene of the air passing through. An important factor in hygienic application is the balance of temperature, humidity and pressure of the air. The effect of the components such as humidifier, fan, filter, damper, cooling coil, heating coil, electric heater, sheet metal etc. should be examined individually.

Using stainless steel instead of galvanized steel does not directly make the unit hygienic. Lots of factors such as air velocity of the unit, air leakages, condensation on the surface, positive-negative pressure balance, cleaning, maintenance, service should be taking into consideration while designing a hygienic air handling unit.

Eneko is taking into account the points below while designing a hygienic unit:

- Stainless steel interior design:** Prevents rusting of the sheet metal of the unit due to humidity and condensation in the air. In addition, surface isn't affected from disinfectant etc.
- High filtration:** The hygienic area is filtered to prevent the bacteria passing through indoor air. M/F/H class filtration is applied according to the hygienic classification required.
- Accessibility and maintenance:** Easy accessibility and maintenance is provided by service cells.
- Temperature, pressure and humidity balance:** Eneko hygienic air handling units are designed to optimize temperature, humidity and pressure balance.
- There are no sharp corners in the unit design.

Eneko hygienic air handling units are certified according to DIN 1946/4 and VDI 6022/1 standards.



What is DIN 1946/4?

According to DIN 1946/4 standard, rooms using for medical purposes are classified as Class I and Class II due to maximum allowed microorganism level. Operation rooms defined as Class I and divided into two with respect to hygienic level. Both Ia and Ib level aims maximum hygienic level and minimum microorganism amount. The classification can only be done by authorized person.

Class Ia applications has to have laminar (turbulent level below 5%) and unidirectional flow (UVU). Class Ib application has to be also laminar flow but not necessary to be unidirectional flow, it can also be bidirectional flow (BVU).

The rooms which do not require high hygienic levels classified as Class II. There is no obligation to have laminar flow and flow can be both unidirectional or bidirectional.

Due to relevant standards, regardless of classification, supply air should be filtered at least F7 and F9 class filter as two-staged filtration. Additionally, if the class of room is Class I, H13 filter is necessary as third stage filtration at supply side. Exhaust air should be filtered by M5 class filter.

Class Ia rooms: orthopedics and traumatology, general surgery, cardiovascular surgery, gynecologic surgery etc.

Class Ib rooms: diagnostic arthroscopy, cardiovascular examination etc.

Class II rooms: patient rooms, physiotherapy areas etc.

What is VDI 6022?

It explains hygienic requirements such as production, operation and maintenance. Aim is to provide technical conditions to protect human health.

Round Around Coil (RAC) Systems

Round Around coil (RAC) is a regenerative heat recovery system which completely separates supply and exhaust line. If supply and exhaust line is especially required as no contact to each other, RAC is preferred system application. Since supply and exhaust line are completely separated from one another; transfer of contaminants like bacteria, odour etc. are prevented. This advantage makes RAC systems preferable for hygienic applications.

In the system, supply and exhaust line can be mounted in completely independent areas and the two lines are connected to each other by a hydraulic circuit. The sensible and latent heat transfer between the two line can be accomplished by the fluid (mostly glycol-water mixture) inside the coils. System effectiveness depends on the design of the system and also water/glycol ration in coils. Drain pan should be used under the coil used in exhaust line.

In Eneko RAC systems, the coils consist of copper tube and aluminum fins. Capacity setting is done by circulation pump. Drain pan and drop eliminator are used for the coil used in exhaust line.

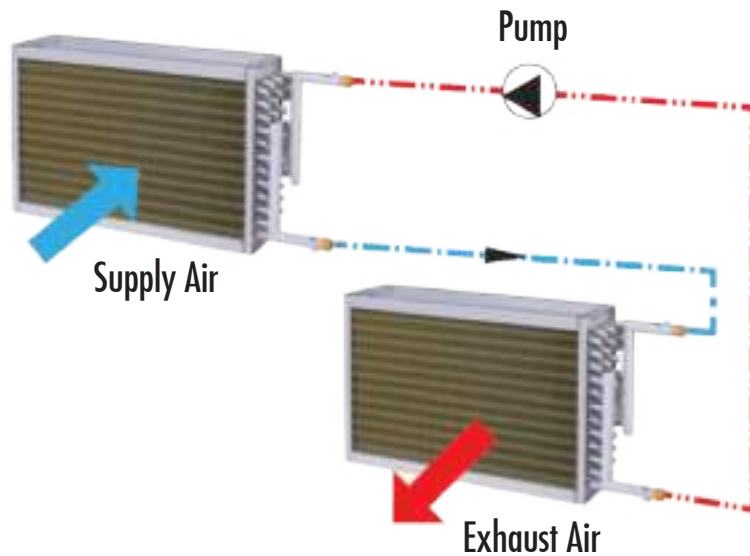

Technical Specifications and Unit Dimensions

EPO HGN/EHU HGN

		ERO HGN/EPO/HGN/EHU HGN										
		010	015	030	055	070	090	125	175	225	300	400
Maximum Air Flow	m ³ /h	1000	1500	3000	5500	6800	8500	15300	18450	25900	30000	40000
Nominal Voltage	V/Hz/f	400/ 50 /3~										

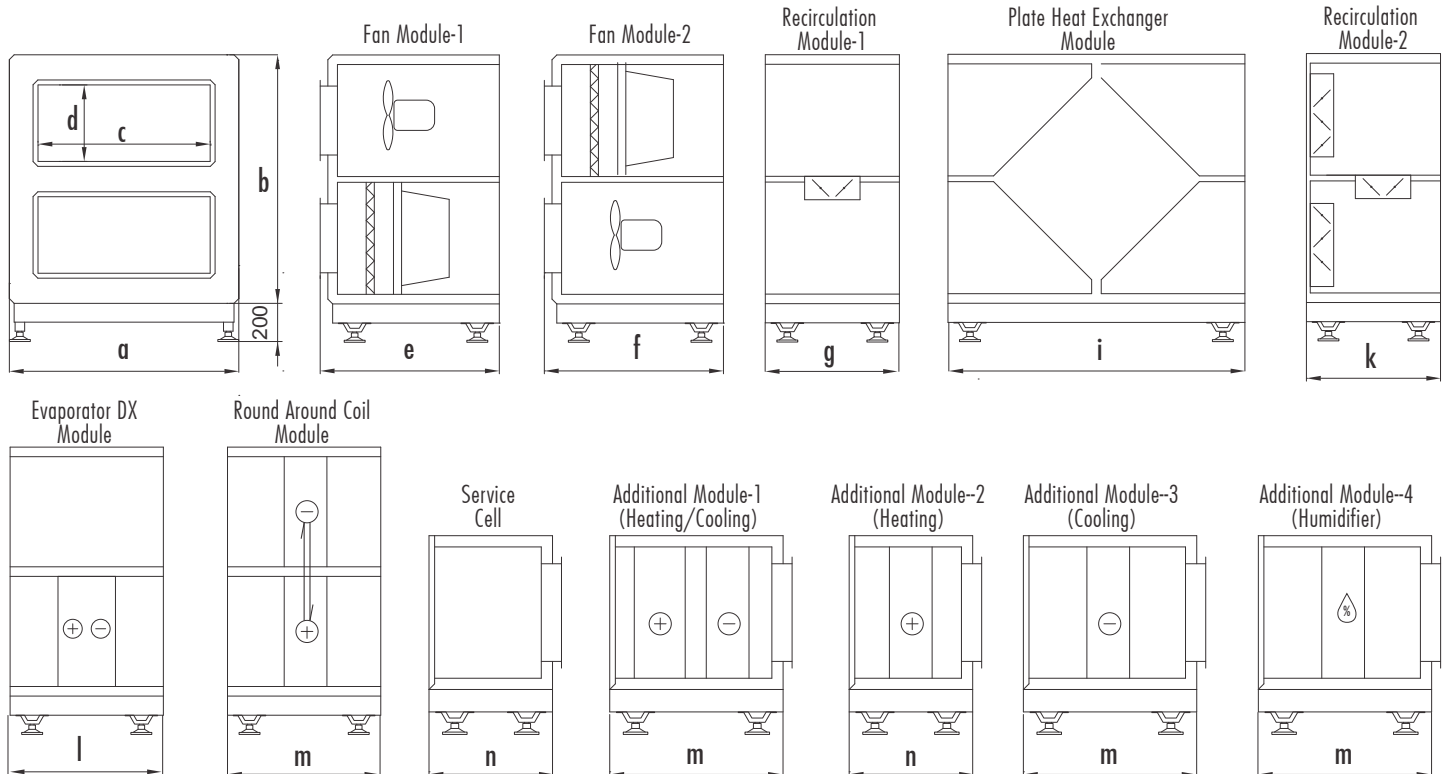

EPO HGN / EHU HGN	a	b	cx d	e	f	g	i	k	l	m	n
010	850	900	550x200	955	955	700	1550	700	800	825	600
015	950	950	650x200	955	955	700	1550	700	800	825	600
030	1200	1300	900x400	1115	1115	700	1550	700	800	825	600
055	1200	1580	900x500	1115	1115	700	1880	700	800	825	600
070	1450	1580	1150x500	1115	1115	700	1880	700	800	825	600
090	1700	1800	1400x600	1115	1115	700	1880	700	800	825	600
125	1950	2200	1650x800	1115	1115	700	2100	700	800	825	600
175	2200	2450	1900x900	1115	1115	700	2300	700	800	825	600
225	2450	2650	2150x1000	1215	1215	700	2435	700	850	825	600
300	3050	2650	2750x900	1215	1215	700	2775	700	850	825	600
400	3600	2800	3300x1100	1215	1215	700	2400	700	850	825	600

Service Space

All measurement values are mm.

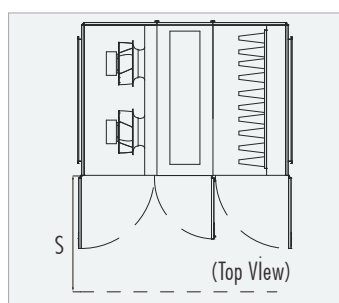

	EPO HGN/EHU HGN 10/15	EPO HGN/EHU HGN 30/55	EPO HGN/EHU HGN 70/90	EPO HGN/EHU HGN 125/175	EPO HGN/EHU HGN 225/300/400
S	1000	1200	1500	2000	2500

All measurement values are mm.

■ EPO HGN Series

100% Fresh Air

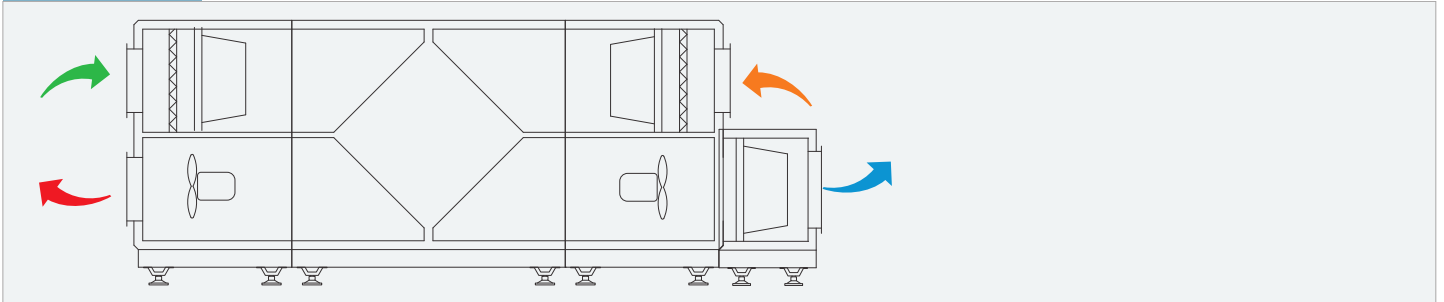

100% Fresh Air - Heating + Cooling Coil

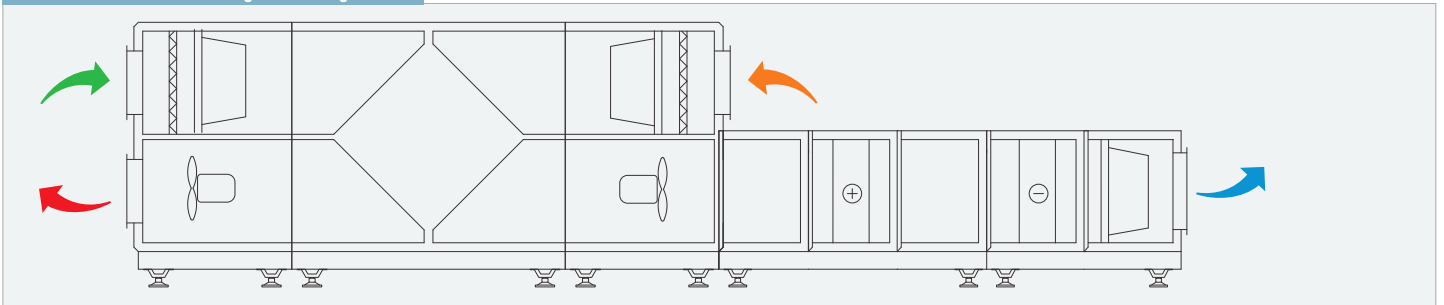

Recirculation Damper - Heating + Cooling Coil + Humidifier

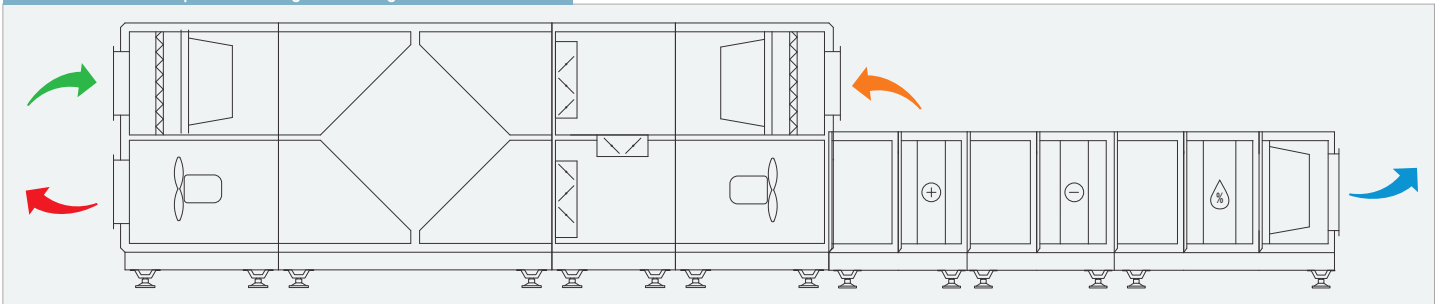

 Outdoor Air
  Supply Air
  Return Air
  Exhaust

Note: Configuration options are not limited with the examples given above, more configuration options are available according to demand.

EHU-D HGN Series

Recirculation Damper - Heating + Cooling Coil

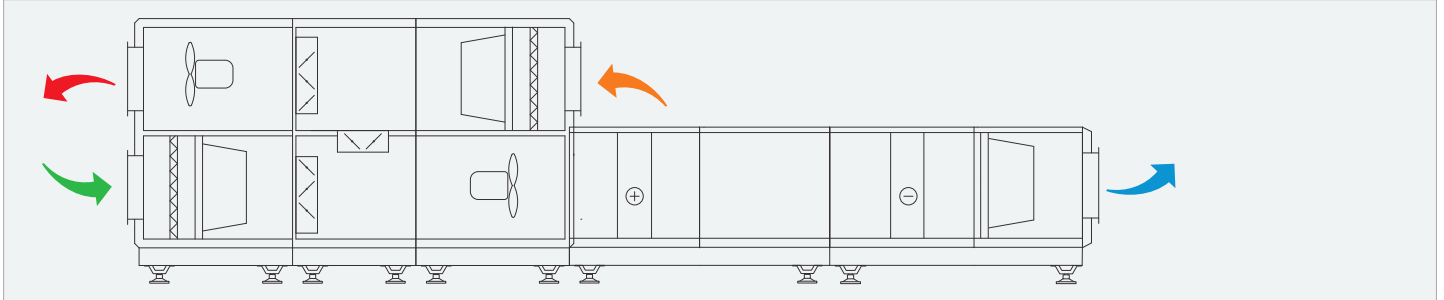

Round Around Coil (RAC)

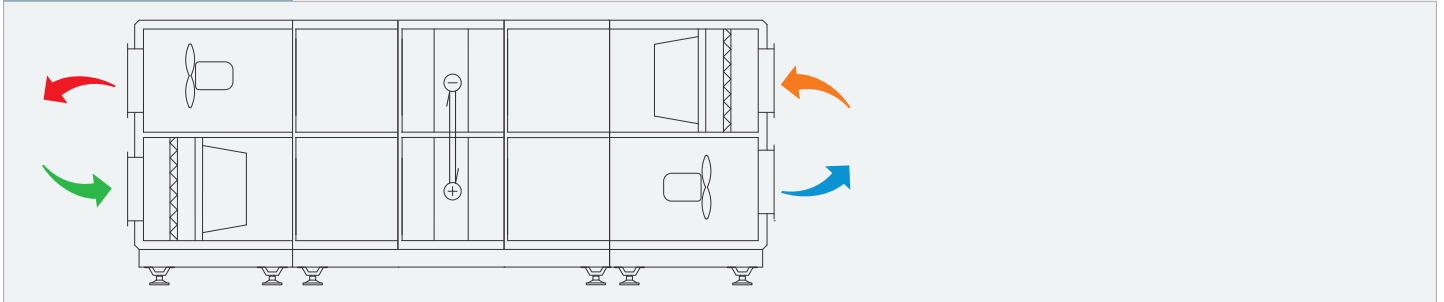

 Outdoor Air
  Supply Air
  Return Air
  Exhaust

Note: Configuration options are not limited with the examples given above, more configuration options are available according to demand.

EHU-S HGN Series

100% Fresh Air

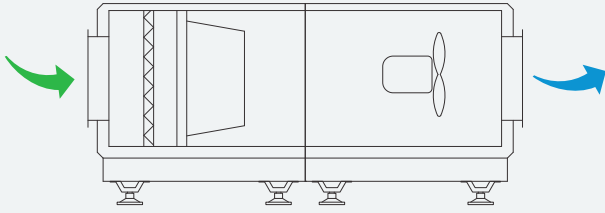

100% Fresh Air - Heating + Cooling Coil

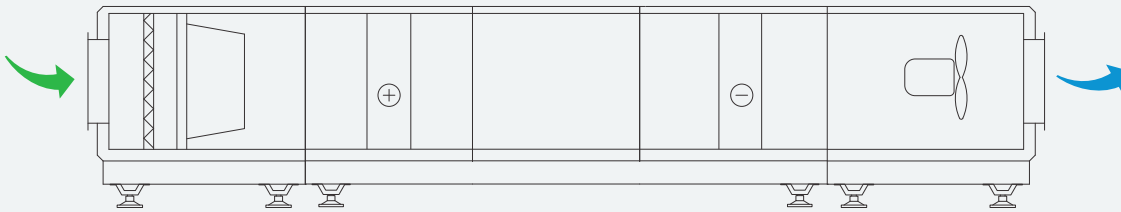

Mixing Damper - Heating + Cooling Coil

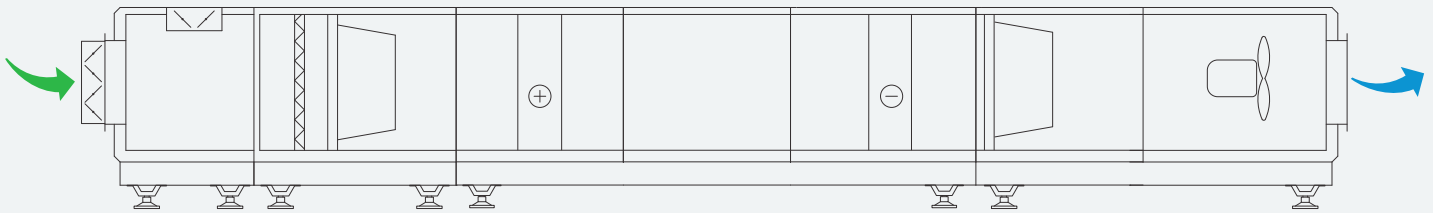



 Outdoor Air  Supply Air

Note: Configuration options are not limited with the examples given above, more configuration options are available according to demand.

■ EPO HGN Series

Automation Options		Control Cards		
Standard	Optional	Standard		Alternative
		Type 1	Type 2	
OA Temperature Sensor		☑	☑	☑
RA Temperature Sensor		☑	☑	☑
SA Temperature Sensor		☑	☑	☑
SA Fan Control		☑	☑	☑
RA Fan Control		☑	☑	☑
Filter Contamination Info		☑	☑	☑
On/Off Damper Control		☑	☑	☑
On/Off By-Pass Damper Control		☑	☑	☑
Modbus RTU		☑	☑	☑
Web Browser (TCP/IP)		☒	☑	☑
	Proportional By-Pass Damper Control	☑	☑	☑
	On/Off Mixing Damper Control	☑	☑	☑
	Proportional Mixing Damper Control	☑	☑	☑
	Proportional Damper Control	☑	☑	☑
	Airflow Control		☑	☑
	Humidity Control	⊖	☑	☑
	CO2 Control		☑	☑
	On/Off Heating Coil	☑	☑	☑
	Proportional Heating Coil	☑	☑	☑
	On/Off Cooling Coil	☑	☑	☑
	Proportional Cooling Coil	☑	☑	☑
	Electrical Pre-Heater	☑	☑	☑
	Electrical After-Heater	☑	☑	☑
	BacNET MSTP	☑	☑	☑



⊖ Only one of them the defined functions is selectable for this control card.

Control Panel		Control Cards		
Panel Type	Panel Descriptions	Standard		Alternative
		Type 1	Type 2	
	Standard-1.1 Hand Panel 1: Wall-mounted type, IP 65 protection class for only front side of panel, Max:50 m communication ability Hand Panel 2: Magnet type, IP 65 protection class for whole panel, Max:50 m communication ability	☑	☑	☒
	Standard-1.2 Magnet type, IP 31 protection class, Max:700 m communication ability	☑	☑	☒
	Alternative Wall-mounted type hand panel, IP 30 protection class, Max:100 m communication ability	☒	☒	☑

EHU-S HGN Serisi

Automation Options		Control Cards		
Standard	Optional	Standard		Alternative
		Type 1	Type 2	
OA Temperature Sensor		☑	☑	☑
SA Fan Control		☑	☑	☑
Filter Contamination Info		☑	☑	☑
On/Off Damper Control		☑	☑	☑
SA Temperature Sensor		☑	☑	☑
Modbus RTU		☑	☑	☑
Web Browser (TCP/IP)		☒	☑	☑
	Proportional Damper Control	☑	☑	☑
	Airflow Control		☑	☑
	Humidity Control	⊖	☑	☑
	CO2 Control		☑	☑
	On/Off Heating Coil	☑	☑	☑
	Proportional Heating Coil	☑	☑	☑
	On/Off Cooling Coil	☑	☑	☑
	Proportional Cooling Coil	☑	☑	☑
	Electrical Pre-Heater	☑	☑	☑
	Electrical After-Heater	☑	☑	☑
	BacNET MSTP	☑	☑	☑



⊖ Only one of them the defined functions is selectable for this control card.

Control Panel		Control Cards		
Panel Type	Panel Descriptions	Standard		Alternative
		Type 1	Type 2	
	Standard-1.1 Hand Panel 1: Wall-mounted type, IP 65 protection class for only front side of panel, Max:50 m communication ability Hand Panel 2: Magnet type, IP 65 protection class for whole panel, Max:50 m communication ability	☑	☑	☒
	Standard-1.2 Magnet type, IP 31 protection class, Max:700 m communication ability	☑	☑	☒
	Alternative Wall-mounted type hand panel, IP 30 protection class, Max:100 m communication ability	☒	☒	☑

■ EHU-D HGN Series

Automation Options		Control Cards		
Standard	Optional	Standard		Alternative
		Type 1	Type 2	
OA Temperature Sensor		☑	☑	☑
RA Temperature Sensor		☑	☑	☑
SA Temperature Sensor		☑	☑	☑
SA Fan Control		☑	☑	☑
RA Fan Control		☑	☑	☑
Filter Contamination Info		☑	☑	☑
Proportional Damper Control		☑	☑	☑
Modbus RTU		☑	☑	☑
Web Browser (TCP/IP)		☒	☑	☑
	On/Off Damper Control	☑	☑	☑
	Airflow Control		☑	☑
	Humidity Control	⊖	☑	☑
	CO2 Control		☑	☑
	On/Off Heating Coil	☑	☑	☑
	Proportional Heating Coil	☑	☑	☑
	On/Off Cooling Coil	☑	☑	☑
	Proportional Cooling Coil	☑	☑	☑
	Electrical Pre-Heater	☑	☑	☑
	Electrical After-Heater	☑	☑	☑
	BacNET MSTP	☑	☑	☑

⊖ Only one of them the defined functions is selectable for this control card.

Control Panel		Control Cards		
Panel Type	Panel Descriptions	Standard		Alternative
		Type 1	Type 2	
	Standard-1.1 Hand Panel 1: Wall-mounted type, IP 65 protection class for only front side of panel, Max:50 m communication ability Hand Panel 2: Magnet type, IP 65 protection class for whole panel, Max:50 m communication ability	☑	☑	☒
	Standard-1.2 Magnet type, IP 31 protection class, Max:700 m communication ability	☑	☑	☒
	Alternative Wall-mounted type hand panel, IP 30 protection class, Max:100 m communication ability	☒	☒	☑

Evaporator & Condenser

Copper tube-aluminum fin type and high efficient evaporator and condenser are used. At the inlet of the evaporator, refrigerant distributor is used for a uniform distribution.

Since air velocity is selected as possible lower value for evaporator and condenser, as a result pressure drop on air side is reduced. There is a stainless steel drain pan under the evaporator and condenser. Also, siphon is given with the unit as standard.

Exhaust and Supply Air Fans

The fans in packaged type energy recovery units with heat pump are equipped with innovative Electronically Commutated EC motor technology. EC motors have higher efficiency and simple speed control. Fan blades have high aerodynamic efficient backward curved design. EC motors reduce the energy consumption and increase the energy efficiency of the unit. With EC Fans, maintenance costs are reduced as the fans are directly connected to the motors; the belt and pulley problems are eliminated.

Exhaust and Supply Air Filters

ERO AC series packaged type energy recovery units with Heat Pump have standard G class pre-filters for both exhaust and supply air streams. A choice of F class final filters can be preferred optionally. G class pre-filters are washable and secured in rigid frames made of galvanized steel. F class final filters are innovative compact filters with increased filtration surface area to reduce initial pressure drop over the filter and also reduce size of units. All the filters comply with EN 779 to meet the requirements of odor absorption and dust arrestment. Fouled filter information is indicated in the control panel by standard installed differential pressure switches however pressure transmitter is also available optionally to observe fouling. Filter sections are designed to ease filter service and changing.

Compressor and Heat Pump Cycle

High efficiency, fully hermetic compressors are used in the packaged type energy recovery units with heat pump. Externally balanced thermostatic expansion valve is used in the unit. The system safety is ensured with low and high pressure pressurestats. The system can work in heating or cooling mode depending on the season selection on the control panel.

Control System Plug&Play

Units are equipped with a microprocessor based control system to meet various design needs. Both electrically and electronically control hardware comes with the unit that's why the unit is "Plug and Play". Exchanger monitoring and speed control, filter monitoring, fan monitoring are standard. With the use of optional IAQ, CO2 sensor or constant flow kit, fans regulate automatically according to user demand. Room control panel is supplied where no BMS protocol is demanded. The panel is BMS compatible and can handle various communication protocols like Modbus, Bacnet and Lonworks. Control System is also capable of controlling heating/cooling capacity when units are used with heating/cooling coils.

Rotary Heat Recovery

ERO AC series packaged type energy recovery units with heat pump have high efficient rotary heat recovery.

Casing & Insulation

The unit's casing is made up of double skinned high corrosion resistive 200 gr/m² galvanize coated steel. 50 mm thickness and 70kg/m³ density of Rockwool insulation between the walls is used for thermal and sound insulation. Screw-adjustable feet are also available as an option under the base frame. The case of unit is painted by electrostatic powdered paint. The unit is constructed in sections to ease transportation, mounting and commissioning. Every section has its own basis and transport slots.



Exhaust and Supply Air Filters

EPO AC series packaged type heat recovery units with heat pump have standard G class pre-filters for both exhaust and supply air streams. A choice of F class final filters can be preferred optionally. G class pre-filters are washable and secured in rigid frames made of galvanized steel. F class final filters are innovative compact filters with increased filtration surface area to reduce initial pressure drop over the filter and also reduce size of units. All the filters comply with EN 779 to meet the requirements of odor absorption and dust arrestment. Fouled filter information is indicated in the control panel by standard installed differential pressure switches however pressure transmitter is also available optionally to observe fouling. Filter sections are designed to ease filter service and changing.

Heat Recovery Exchanger (Aluminum)

EPO AC series packaged type heat recovery units with heat pump have high efficient aluminum crossflow, plate heat recovery exchangers with Eurovent certification.

Control System  **Plug&Play**

Units are equipped with a microprocessor based control system to meet various design needs. Both electrically and electronically control hardware comes with the unit that's why the unit is "Plug and Play". Exchanger monitoring and speed control, filter monitoring, fan monitoring are standard. With the use of optional IAQ, CO2 sensor or constant flow kit, fans regulate automatically according to user demand. Room control panel is supplied where no BMS protocol is demanded. The panel is BMS compatible and can handle various communication protocols like Modbus, Bacnet and Lonworks. Control System is also capable of controlling heating/cooling capacity when units are used with heating/cooling coils.

Casing & Insulation

The unit's casing is made up of double skinned high corrosion resistive 200 gr/m² galvanize coated steel. 50 mm thickness and 70kg/m³ density of Rockwool insulation between the walls is used for thermal and sound insulation. Screw-adjustable feet are also available as an option under the base frame. The case of unit is painted by electrostatic powdered paint. The unit is constructed in sections to ease transportation, mounting and commissioning. Every section has its own basis and transport slots.

Evaporator & Condenser

Copper tube-aluminum fin type and high efficient evaporator and condenser are used. At the inlet of the evaporator, refrigerant distributor is used for a uniform distribution. Since air velocity is selected as possible lower value for evaporator and condenser, as a result pressure drop on air side is reduced. There is a stainless steel drain pan under the evaporator and condenser. Also, siphon is given with the unit as standard.

Compressor and Heat Pump Cycle

High efficiency, fully hermetic compressors are used in the packaged type heat recovery units with heat pump. Externally balanced thermostatic expansion valve is used in the unit. The system safety is ensured with low and high pressure pressurestats. The system can work in heating or cooling mode depending on the season selection on the control panel.

Exhaust and Supply Air Fans

The fans in packaged type energy recovery units with heat pump are equipped with innovative Electronically Commutated EC motor technology. EC motors have higher efficiency and simple speed control. Fan blades have high aerodynamic efficient backward curved design. EC motors reduce the energy consumption and increase the energy efficiency of the unit. With EC Fans, maintenance costs are reduced as the fans are directly connected to the motors; the belt and pulley problems are eliminated.

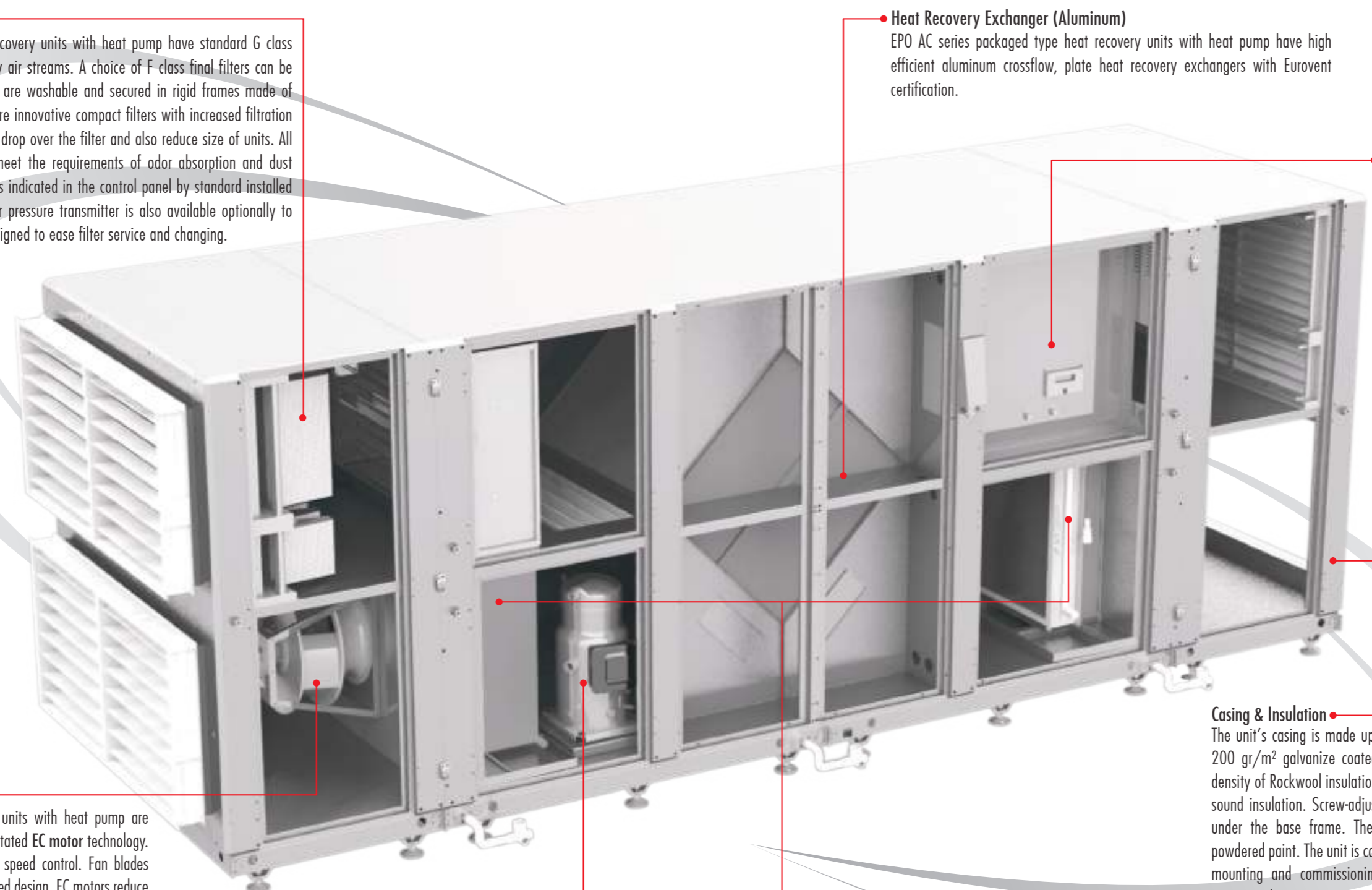

Exhaust and Supply Air Fans

The fans in air handling units without heat recovery are equipped with innovative Electronically Commutated EC motor technology. EC motors have higher efficiency and simple speed control. Fan blades have high aerodynamic efficient backward curved design. EC motors reduce the energy consumption and increase the energy efficiency of the unit. With EC Fans, maintenance costs are reduced as the fans are directly connected to the motors; the belt and pulley problems are eliminated.

Exhaust and Supply Air Filters

EHU AC series air handling units without heat recovery have standard G class pre-filters for both exhaust and supply air streams. A choice of F class final filters can be preferred optionally. G class pre-filters are washable and secured in rigid frames made of galvanized steel. F class final filters are innovative compact filters with increased filtration surface area to reduce initial pressure drop over the filter and also reduce size of units. All the filters comply with EN 779 to meet the requirements of odor absorption and dust arrestment. Fouled filter information is indicated in the control panel by standard installed differential pressure switches however pressure transmitter is also available optionally to observe fouling. Filter sections are designed to ease filter service and changing.

Compressor and Heat Pump Cycle

High efficiency, fully hermetic compressors are used in the packaged type heat recovery units with heat pump. Externally balanced thermostatic expansion valve is used in the unit. The system safety is ensured with low and high pressure pressurestats. The system can work in heating or cooling mode depending on the season selection on the control panel.

Control System  Plug&Play

Units are equipped with a microprocessor based control system to meet various design needs. Both electrically and electronically control hardware comes with the unit that's why the unit is "Plug and Play". Filter monitoring, fan monitoring, DX system monitoring are standard. With the use of optional IAQ, CO2 sensor or constant flow kit, fans regulate automatically according to user demand. Room control panel is supplied where no BMS protocol is demanded. The panel is BMS compatible and can handle various communication protocols like Modbus, Bacnet and Lonworks. Control System is also capable of controlling heating/cooling capacity when units are used with heating/cooling coils.

Evaporator & Condenser

Copper tube - aluminum fin type and high efficiency evaporator and condenser are used. At the entrance of the evaporator, refrigerant distributor is used for a uniform distribution. Since the pressure drops on the air side are reduced, the air speed lower value is selected for evaporator and condenser. There is a stainless steel drain pan under the evaporator and condenser. Also, the collective siphon is given with the unit as standard.

Casing & Insulation

The unit's casing is made up of double skinned high corrosion resistive 200 gr/m² galvanize coated steel. 50 mm thickness and 70kg/m³ density of Rockwool insulation between the walls is used for thermal and sound insulation. Screw-adjustable feet are also available as an option under the base frame. The case of unit is painted by electrostatic powdered paint. The unit is constructed in sections to ease transportation, mounting and commissioning. Every section has its own basis and transport slots.



■ ERO AC / EPO AC / EHU AC

In order to ensure indoor air quality in buildings, stale indoor air must be exhausted and conditioned fresh air must be supplied. With the modern approach in energy consumption for HVAC applications, fresh air must be conditioned by consuming minimum electrical and thermal energy. Heat pump systems are available for ERO AC/EPO AC units with very low energy consumption and higher COP than traditional systems to condition fresh air to design temperature. In addition, EHU-AC series units are produced without heat recovery. ERO AC units have the heat pump cycle integrated inside the unit so no additional outdoor units are needed. Because of the high temperature and humidity efficiency of the rotor, compressor powers are minimized. As a result of the humidity transfer of the rotor, the power consumption due to latent heat of the fresh air is also minimized.



After energy and humidity transfer in rotary heat exchanger in between return and supply air, return air passes through condenser in summer times (evaporator in winter times). Thus, last energy lefted in exhaust air is used and COP value of the heat pump reached maximum level.

All required sensors and electronic card are supplied with ERO AC unit as standard. Unit checks outdoor air temperature, indoor air temperature, set temperature and season selection; if all values are appropriate to work in free-cooling mode, compressor and rotary heat exchanger is stopped.

If no humidity transfer is required, then EPO AC unit is preferred. Cross-flow heat exchangers with aluminum plates which performs sensible heat transfer are used in EPO AC units. After heat transfer in heat exchanger, required supply air is achieved by heat pump.

After heat transfer in plate heat exchanger in between return and supply air, return air passes through condenser in summer times (evaporator in winter times). Thus, last energy lefted in exhaust air is used and COP value of the heat pump reached maximum level.

All required sensors and electronic card are supplied with EPO AC unit as standard. Unit checks outdoor air temperature, indoor air temperature, set temperature and season selection; if all values are appropriate to work in free-cooling mode, compressor and rotary heat exchanger is stopped.

EHU AC units are preferred in areas where operation with 100% fresh air is desired or where fresh air ratio is low.

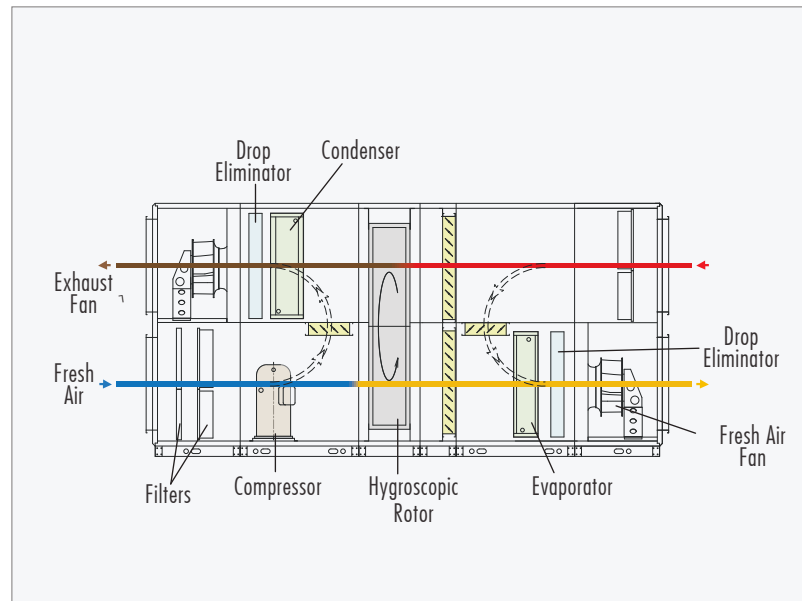

Technical Specifications and Unit Dimensions

■ ERO AC / EPO AC / EHU AC Series

		ERO AC / EPO AC / EHU AC								
		010	015	030	055	070	090	125	175	225
Maximum Air Flow	m ³ /h	1000	1500	3000	5500	6800	8500	15300	18450	25900
Nominal Voltage	V/Hz/f	400/ 50 /3~								

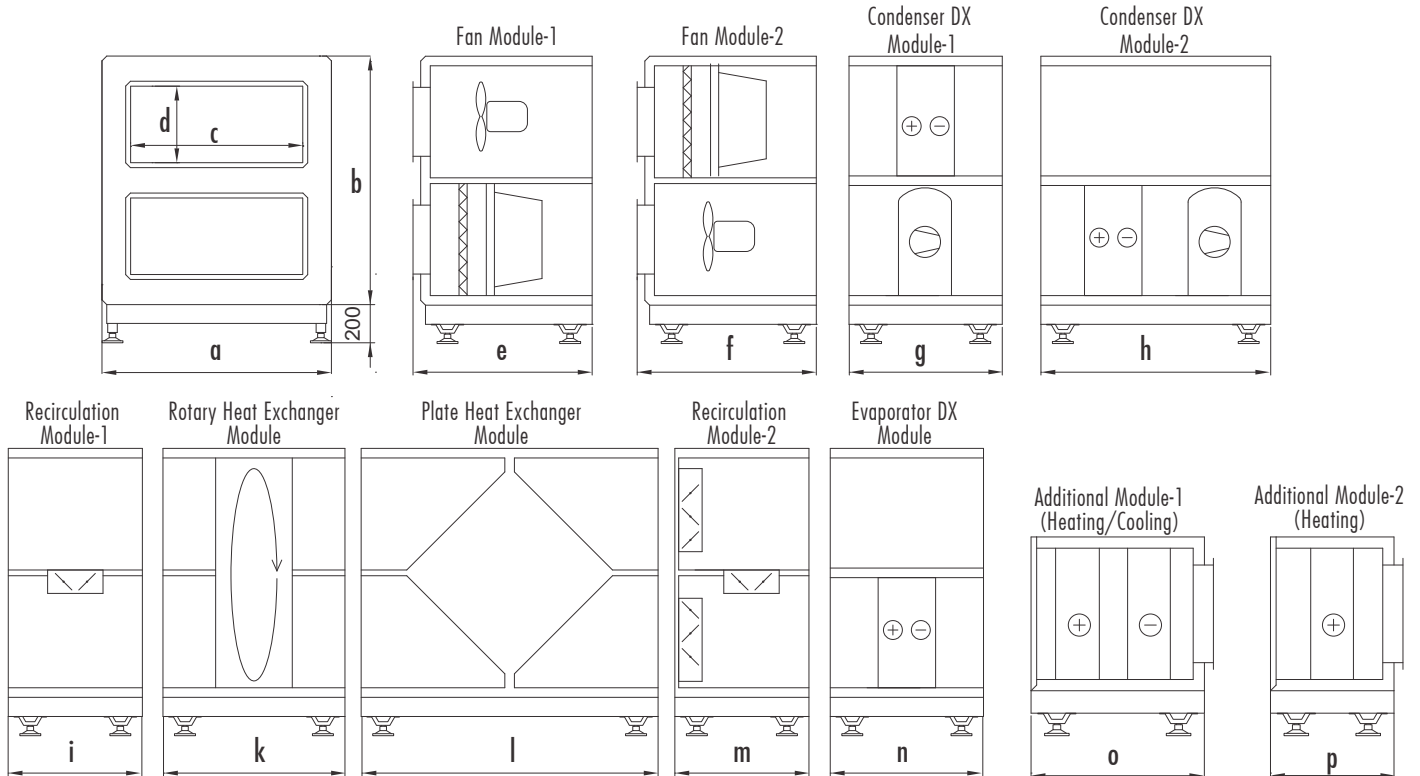

ERO AC/EPO AC/EHU AC	a	b	cx/d	e	f	g	h	i	k	l	m	n	o	p
010	850	900	550x200	955	955	800	1200	700	950	1550	700	800	825	600
015	950	950	650x200	955	955	800	1200	700	950	1550	700	800	825	600
030	1200	1300	900x400	1115	1115	800	1200	700	950	1550	700	800	825	600
055	1200	1580	900x500	1115	1115	800	1200	700	950	1850	700	800	825	600
070	1450	1580	1150x500	1115	1115	800	1200	700	950	1880	700	800	825	600
090	1700	1800	1400x600	1115	1115	800	1200	700	950	1880	700	800	825	600
125	1950	2200	1650x800	1115	1115	800	1200	700	950	2100	700	800	825	600
175	2200	2450	1900x900	1115	1115	800	1260	700	820	2300	700	800	825	600
225	2450	2650	2150x1000	1215	1215	1000	1260	700	820	2400	700	850	825	600

All measurement values are mm.

Service Space

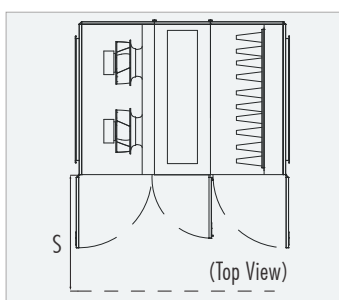

	ERO AC/EPO AC/EHU AC 10/15	ERO AC/EPO AC/EHU AC 30/55	ERO AC/EPO AC/EHU AC 70/90	ERO AC/EPO AC/EHU AC 125/175	ERO AC/EPO AC/EHU AC 225
S	1000	1200	1500	2000	2500

All measurement values are mm.

■ ERO AC Series

100% Fresh Air

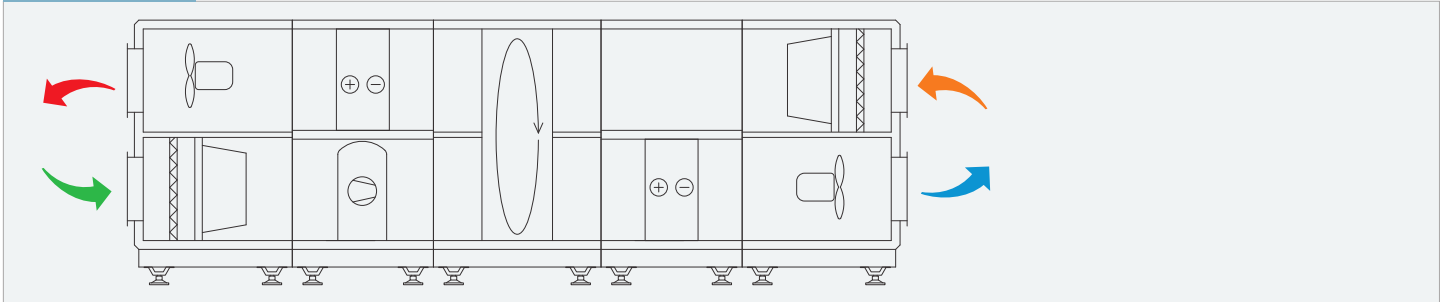

Recirculation Damper

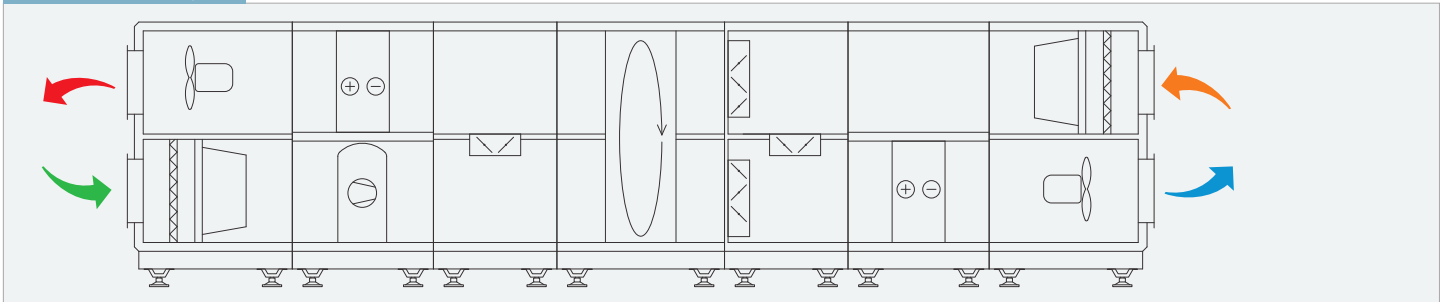

Note: Configuration options are not limited with the examples given above, more configuration options are available according to demand.

■ EPO AC Series

100% Fresh Air

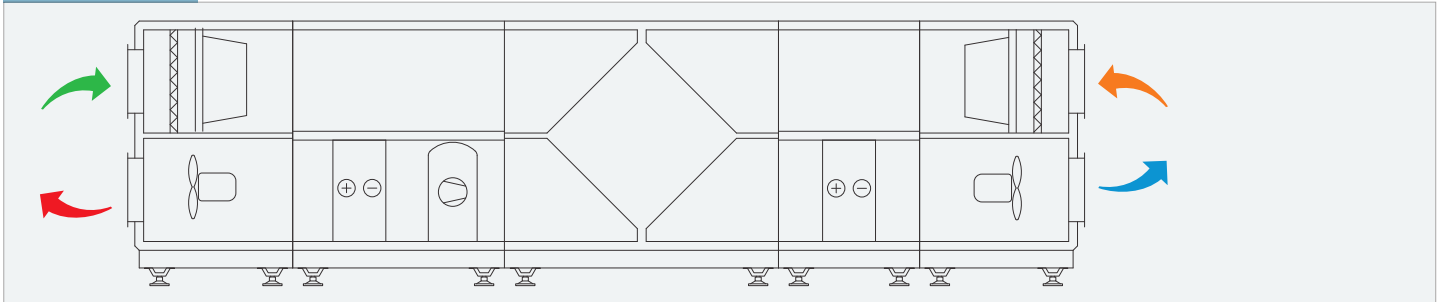

Recirculation Damper

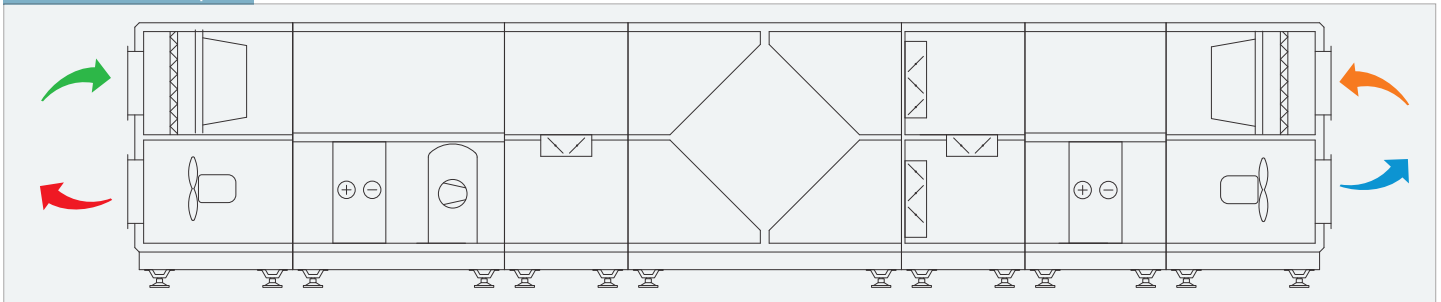

 Outdoor Air  Supply Air  Return Air  Exhaust

Note: Configuration options are not limited with the examples given above, more configuration options are available according to demand.

■ EHU AC Series

100% Fresh Air

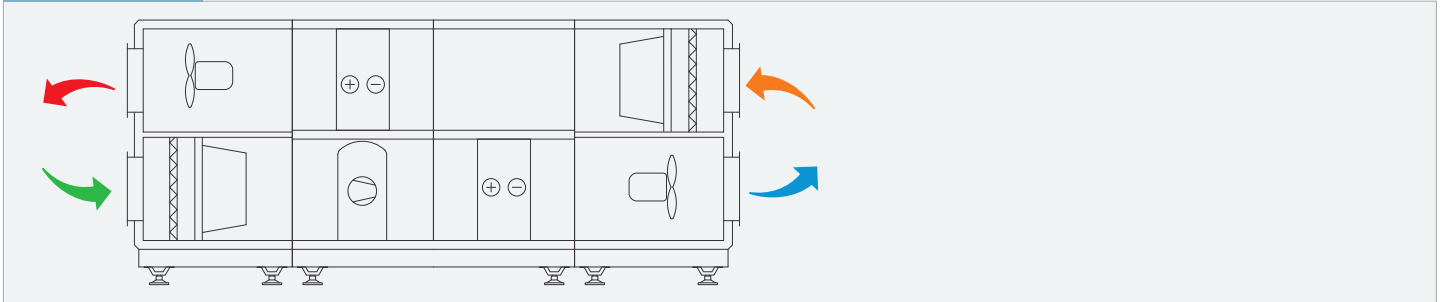

Recirculation Damper

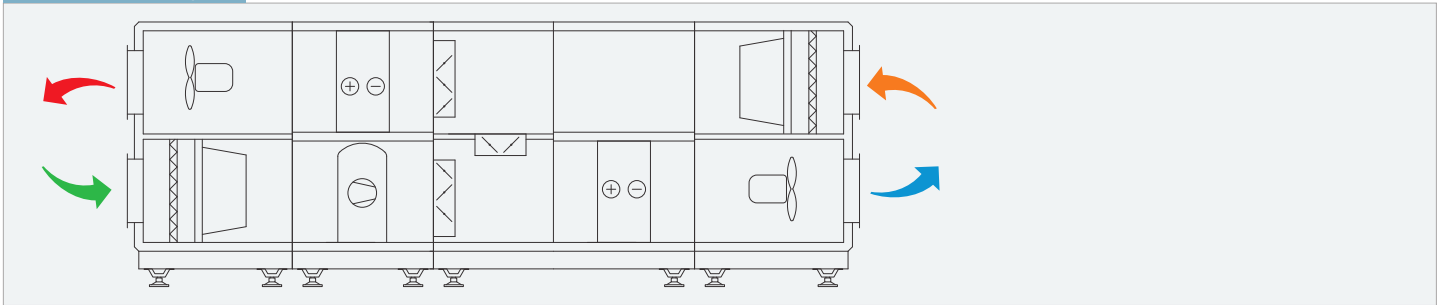

 Outdoor Air

 Supply Air



 Return Air

 Exhaust

Note: Configuration options are not limited with the examples given above, more configuration options are available according to demand.



■ ERO AC Series

Automation Options		Control Cards
Standard	Optional	Standard
OA Temperature Sensor		☑
RA Temperature Sensor		☑
SA Temperature Sensor		☑
SA Fan Control		☑
RA Fan Control		☑
On/Off Damper Control		☑
Compressor Control		☑
4 Way Control		☑
Filter Contamination Info (Time)		☑
Modbus RTU		☑
Web Browser (TCP/IP)		☑
	Proportional Rotor Control	☑
	Proportional Damper Control	☑
	Airflow Control	☑
	Humidity Control	☑
	CO2 Control	☑
	On/Off Heating Coil	☑
	Proportional Heating Coil	☑
	On/Off Cooling Coil	☑
	Proportional Cooling Coil	☑
	Electrical Pre-Heater	☑
	Electrical After-Heater	☑
	BacNET MSTP	☑
	Weekly Timer	☑
	Filter Contamination Info (DPS)	☑

Control Panel		Control Cards
Panel Type	Panel Descriptions	Standard
	Standard-1.1 Hand Panel 1: Wall-mounted type, IP 65 protection class for only front side of panel, Max:50 m communication ability Hand Panel 2: Magnet type, IP 65 protection class for whole panel, Max:50 m communication ability	☑
		Standard-1.2 Magnet type, IP 31 protection class, Max:700 m communication ability



■ EPO AC Series

Automation Options		Control Cards
Standard	Optional	Standard
OA Temperature Sensor		☑
RA Temperature Sensor		☑
SA Temperature Sensor		☑
SA Fan Control		☑
RA Fan Control		☑
On/Off Damper Control		☑
On/Off By-Pass Damper Control		☑
Compressor Control		☑
4 Way Control		☑
Filter Contamination Info (Time)		☑
Modbus RTU		☑
Web Browser (TCP/IP)		☑
	Proportional By-Pass Damper Control	☑
	On/Off Mix Damper Control	☑
	Proportional Mix Damper Control	☑
	Proportional Damper Control	☑
	Airflow Control	☑
	Humidity Control	☑
	CO2 Control	☑
	On/Off Heating Coil	☑
	Proportional Heating Coil	☑
	On/Off Cooling Coil	☑
	Proportional Cooling Coil	☑
	Electrical Pre-Heater	☑
	Electrical After-Heater	☑
	BacNET MSTP	☑
	Weekly Timer	☑
	Filter Contamination Info (DPS)	☑

Control Panel		Control Cards
Panel Type	Panel Descriptions	Standard
	Hand Panel 1: Wall-mounted type, IP 65 protection class for only front side of panel, Max:50 m communication ability Hand Panel 2: Magnet type, IP 65 protection class for whole panel, Max:50 m communication ability	☑
		
	Magnet type, IP 31 protection class, Max:700 m communication ability	☑

■ EHU AC Series

Automation Options		Control Cards
Standard	Optional	Standard
OA Temperature Sensor		☑
RA Temperature Sensor		☑
SA Temperature Sensor		☑
SA Fan Control		☑
RA Fan Control		☑
Filter Contamination Info (Time)		☑
Compressor Control		☑
4 Way Control		☑
Proportional Damper Control		☑
Modbus RTU		☑
Web Browser (TCP/IP)		☑
	On/Off Damper Control	☑
	Airflow Control	☑
	Humidity Control	☑
	CO2 Control	☑
	On/Off Heating Coil	☑
	Proportional Heating Coil	☑
	On/Off Cooling Coil	☑
	Proportional Cooling Coil	☑
	Electrical Pre-Heater	☑
	Electrical After-Heater	☑
	BacNET MSTP	☑

Control Panel		Control Cards
Panel Type	Panel Descriptions	Standard
	Standard-1.1 Hand Panel 1: Wall-mounted type, IP 65 protection class for only front side of panel, Max:50 m communication ability Hand Panel 2: Magnet type, IP 65 protection class for whole panel, Max:50 m communication ability	☑
		Standard-1.2 Magnet type, IP 31 protection class, Max:700 m communication ability

■ Sound Attenuator

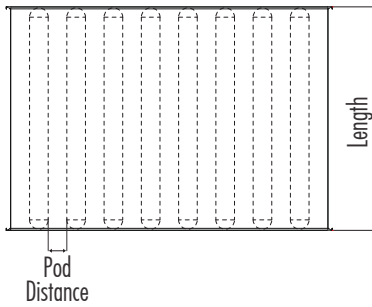
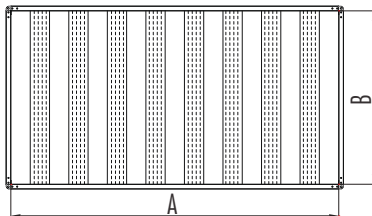

	A	B
ERO/EPO/EHU 030	800	400
ERO/EPO/EHU 055	800	500
ERO/EPO/EHU 070	1050	500
ERO/EPO/EHU 090	1300	600
ERO/EPO/EHU 125	1550	800
ERO/EPO/EHU 175	1800	900
ERO/EPO/EHU 225	2050	1000
ERO/EPO/EHU 275	2300	1000
ERO/EPO/EHU 300	2650	1000
ERO/EPO/EHU 400	3300	1100

Characteristics (Pod width 200 mm)

Length mm	63	125	250	500	1k	2k	4k	8k	Pressure drop coefficient, β
600	3	4	11	16	23	19	14	9	2,8
1000	4	9	20	30	42	36	23	17	3,3
1500	5	14	29	44	50	50	35	22	4,2
2000	8	22	48	50	50	50	48	31	5

*Pod distance 80 mm

Length mm	63	125	250	500	1k	2k	4k	8k	Pressure drop coefficient, β
600	2	5	10	14	20	15	9	7	1,6
1000	3	8	18	27	37	29	19	14	1,9
1500	5	12	26	40	50	44	27	18	2,4
2000	6	16	34	50	50	50	33	22	2,9

*Pod distance 100 mm

Length mm	63	125	250	500	1k	2k	4k	8k	Pressure drop coefficient, β
600	2	4	9	13	17	12	9	6	1
1000	3	7	16	25	32	24	16	11	1,3
1500	4	11	23	36	50	36	22	15	1,5
2000	5	14	31	48	50	47	28	18	1,8

*Pod distance 120 mm

Pressure drop of the sound attenuator is calculated with β, Pressure drop coefficient
 $\Delta P = \beta \times V^2$

V face velocity (m/s), is calculated by dividing Air Flow (m³/s) to the area of the connected duct spigot.

$$\text{Face Velocity, } V \text{ (m / s)} = \frac{\text{Air Flow (m}^3\text{/s)}}{\text{Spigot Area (m}^2\text{)}}$$

	ERO/EPO/EHU				
	030	055	070	090	125
Duct Connection Spigot Dimension mm	800 x 400	800 x 500	1050 x 500	1300 x 600	1550 x 800
Duct Connection Spigot Area m ²	0.32	0.4	0.525	0.78	1.24

	ERO/EPO/EHU			
	175	225	300	400
Duct Connection Spigot Dimension mm	1800 x 900	2050 x 1000	2650 x 1000	3300 x 1100
Duct Connection Spigot Area m ²	1.62	2.05	2.65	3.63

■ Recirculation Module

Units are designed for 100% fresh air operation. But for some operation, period user can demand for conditioning indoor space before meeting IAQ demands. For example the period before the conference hall, before the people starts to work in their offices, before a concert in a concert hall, disco etc.

For applications similar to these HVAC installations, by-pass module is designed for each capacity for units. By-Pass module is controlled with remote control panel between 0-100 % opening.



Damper 100% Open:

The unit operates with 100% of return air. Indoor air is by-passed before entering the heat recovery exchanger. By-passed air is conditioned with heating/cooling coils and blown indoors. Only supply air fans and heating/cooling coils are operating in this mode. The rotor and exhaust fans are switched off

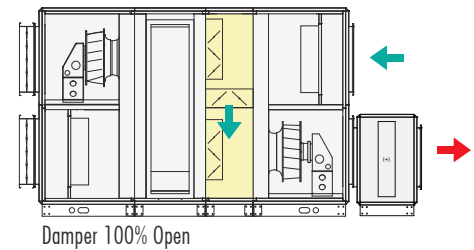

Damper Closed:

The unit operates with 100% of fresh air. Indoor air is introduced to the heat recovery exchanger to exchange heat and humidity (only in the rotary model) and then exhausted to outdoors. Fresh air enters the heat recovery exchanger to deliver the heat and humidity of the exhausted air, then supplied indoors after heating/cooling process over the coils. Both supply air and exhaust air fans and the heat recovery exchanger is operating in this mode.

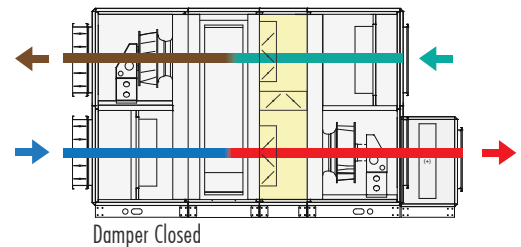

Damper Modulation:

The unit operates with mixture of supply and return air. Some portion of the return air is mixed with fresh air after the heat recovery exchanger and introduces indoors after heating /cooling process over the coils. Both supply air and exhaust air fans and the heat recovery exchanger is operating in this mode, but exhaust air fan speed is modulated.

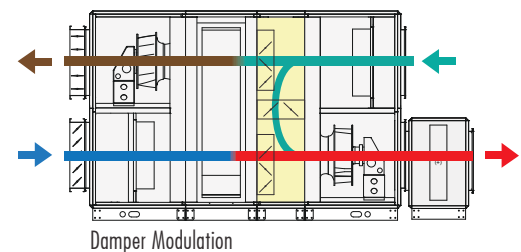

■ Electric Heaters



For extreme climates where outdoor air can be lower than (for ERO -12°C, for EPO -5°C) air electric heaters are advised to be used with units against freezing in both rotary wheels and aluminum plate heat exchangers. The capacity is controlled with step according to outdoor air temperature.

Stainless steel resistances are used for heating elements. 2 different thermostats are installed to protect the heating elements against overheating. The control system ensures safety by operating the fans for additional 2 minutes even after the unit is turned off to cool down heating elements.

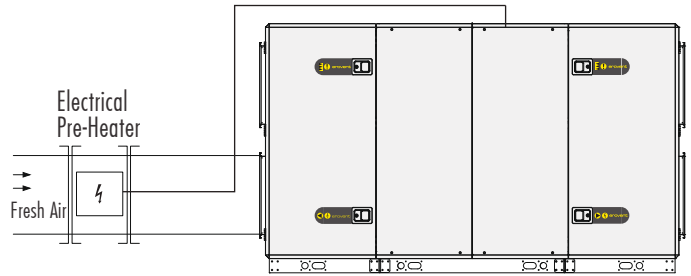

■ Constant Flow Kit



In HVAC applications constant flow kits are used. Constant flow kit consists of pressure measurement blades to measure the difference between static and total pressure transmitter to calculate air velocity from the pressure difference. The pressure difference between total and static pressure are received from the blades installed to the ducting system and the velocity is calculated with given formula;

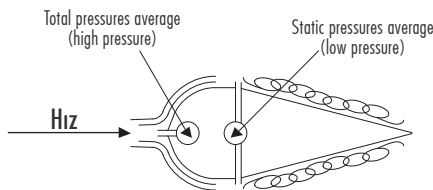

$$\text{Velocity} \left(\frac{m}{s} \right) = K_L \times \sqrt{P_T - P_S}$$

$$\text{Air Flow} \left(\frac{m^3}{h} \right) = K_L \times \sqrt{P_d} \times S \times 3600$$

K_L = Blade Factor
 P_T = Total Pressure
 P_S = Static Pressure
 S = Duct Section (m²)
 $P_d = P_T - P_S$ = Dynamic Pressure
 Factor of Velocity Calculation $K_L = 1$

According to the set air flow, Constant Flow Kit regulated the EC fans automatically. Even the filters become contaminated, or the duct pressure drop is higher the user ensures adequate air flow to the system.

■ Humidifier

Steam humidifiers are available for units. The humidifiers are installed in a separate section with stainless steel drain pan. Standard control turns on or off the humidifier where Close Control Model modulates the capacity between 8% to 100% according to the demand indoors. Standard capacities are designed for each model.

■ Ventilation on Demand



Ventilation on Demand is available with units by means of Air Quality Sensor, CO₂ sensor or RH% sensor. Air Quality Sensor measures volatile organic compounds in the air. VOC, volatile organic compounds, is the common name for organic substances suspended in the air like gases or vapors. VOCs include scent and taste particles, tobacco smoke, building chemicals, solvents, disintegrating gases and products of oxidation.

Air Quality Sensor is mounted to the return air duct and is connected to control system. The set point for the desired indoor air quality is set during the installation. According to the demand indoors, units are modulated automatically by the sensor. Annual energy consumption of the unit is reduced as a result of the modulation, ending in reduction in energy costs.

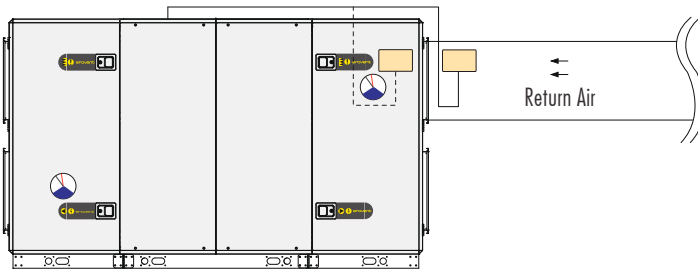

For ventilation on demand function the sensors (IAQ, CO₂ or RH%) can be mounted both to the return air duct or to the unit. 5 meters of wiring for powering the sensor and data transfer is delivered with the sensors. The sensor transmits 0-10V output signal according to the set value and the measured value. The signal is received by the control system and both supply and exhaust air fans speed regulates according indoor air demands.

■ Pressure Gauge



Pressure Gauge is used as an accessory EPG to monitor differential pressure of filters or fans. Ingrid protection is IP54 standard. Pressure Gauge can measure between 0-500Pa.

■ Communication



Control System can communicate in modbus protocol that enables to be communicated between the Building Management System and the unit.

In addition to Modbus, control system supports also LonWorks, BACnet protocols.

In addition, if the customer gives approval the units can be monitored remotely by Eneko service department.



GENERAL

The sale of all Products of ENEKO shall exclusively be made on the basis of these General Terms and Conditions of Sales. Any other conditions and General Conditions of Purchase of the Buyer are not accepted.



OFFERS

Our offers are non-binding and without obligation. Contracts for delivery and all other agreements (including subsidiary agreements) as well as declarations of our representatives shall only become legally binding for us after written confirmation. We do not render planning service.

Proposals made and information provided by our representatives shall be non-binding. Illustrations, drawings, dimensions and weights or other performance data shall only be binding if this is expressly agreed in writing.



TERMS OF ORDER

Purchase orders shall be sent to ENEKO in written form and shall be non-binding unless they are accepted by written confirmation (order confirmation) from ENEKO. Each order shall include properly identified Products ordered and relevant shipping dates.



PRICE OF THE GOODS

Prices are net Ex Works according to current Incoterms unless stated otherwise and do not include any kind of taxes. Prices are valid at the date of delivery will be applied. We reserve the right to adjust prices for confirmed orders as well to reflect any increase in our costs for any reason beyond our control like force majeure, shortage of primary material or labor strikes, official orders, transportation or similar problems. In this case, a new price agreement shall be required for higher rates. If such an agreement is not made, we shall be entitled to withdraw from the contract by written notice within 15 days.



TERMS OF PAYMENT

Payments shall be carried out according to the contractual terms as defined and set forth in the order confirmation. If the payment conditions have not been agreed upon conclusion of the contract, the payment terms and payment dates specified in our invoices shall be binding. Deadlines for discounts and periods allowed for payment shall begin to run upon receipt of the invoice. Payments by draft, bills of Exchange or anyway extended payments shall mean neither credit novation, nor prejudice to the Retention of Title agreement, nor to territorial competence. If buyer fails to make payment by due date, we are entitled to charge the buyer with a relevant interest on the unpaid amount.



TERMS OF DELIVERY

Delivery time information is only approximate. We shall only be in default if the performance is due and a written demand for payment was issued. Delivery day is the day of dispatch Ex Works. We shall also not be liable with regard to bindingly agreed periods and dates in the event of delays in delivery and of performance due to force majeure and events which considerably complicate or make delivery impossible not only temporarily-strike lockout, breakdown, delay in supply with important raw and auxiliary materials even if the delay occurs at our supplier, in particular. These delays entitle us to postpone delivery for the period of the impediment plus a reasonable start-up period or to withdraw from the contract as a whole or in part. If delivery time is extended or we are released from our delivery commitment, the buyer may not derive a claim for damages from it. However, we may only rely on the circumstances mentioned if we notify the buyer immediately. We shall be entitled to make part deliveries. Any part delivery shall be considered as independent transaction. In case of default, our liability is limited to contract-typical foreseeable damage.



SHIPMENT

Shipment is made for the buyer's account. Mode of shipment and shipping route, transport and packaging and other securities respectively shall be at our choice. We shall be entitled, however, not obliged to insure deliveries in the name and for account of the buyer. Risk passes to the buyer when shipment is handed over to the person performing the transport or left our Works for shipment. If shipment is delayed upon buyer's request, risk passes to the buyer with the ready for shipment note. If ordered goods are rejected after the ready for shipment note, we shall be entitled to request payment and store the goods at buyer's expense. Discharge of the goods is made at buyer's expense.



RETENTION OF TITLE

In any event ENEKO shall retain full ownership of all materials supplied whilst the payment conditions of the entire amount have not been complied with, said materials may be removed from the customer at our request. Should the customer be declared bankrupt or insolvent and has not made paid the entire amount of payments. ENEKO shall be entitled to recover the goods. ENEKO may interrupt the supply without incurring any liability whatsoever if he had notice of or became aware of a decrease in the creditworthiness of the purchaser or if any of the existing negotiable instruments or debts were not properly complied with, shall result as being unpaid and protested.



WARRANTY

ENEKO Products are under warranty (defect in material or workmanship) for 2 years from the date of sale reflected on the invoice. Under this warranty, ENEKO is under the obligation to replace the part requested under warranty.

The followings are excluded from ENEKO warranty:

- Normal wear and tear
- Defective assembly or handling
- Third party compensation

Parts the subject of a claim shall be sent to our warehouse as carriage paid with relevant report completely filled in, wherein the parts shall be subjected to analysis.



LIABILITY

ENEKO, for any losses/damages, shall only be responsible within the limits of the law. Owing to basic obligations undertaken by simple negligence, if the contract is violated, ENEKO's liability shall be limited to compensate for losses which are emerged specific and predictable. ENEKO shall not carry any responsibility in case of a single negligence in breach of non-essential contractual obligations.



PROPERTY RIGHTS

The purchaser in no event and under no circumstances whatsoever shall publish or use the trademark, trade name or logo of ENEKO without a prior written permission.



GOVERNING LAW AND JURISDICTION

This agreement shall be governed with all aspects of the Turkish Law. The courts of Izmir/Turkey shall have an exclusive jurisdiction to adjudicate any dispute arising under or in connection with this agreement.

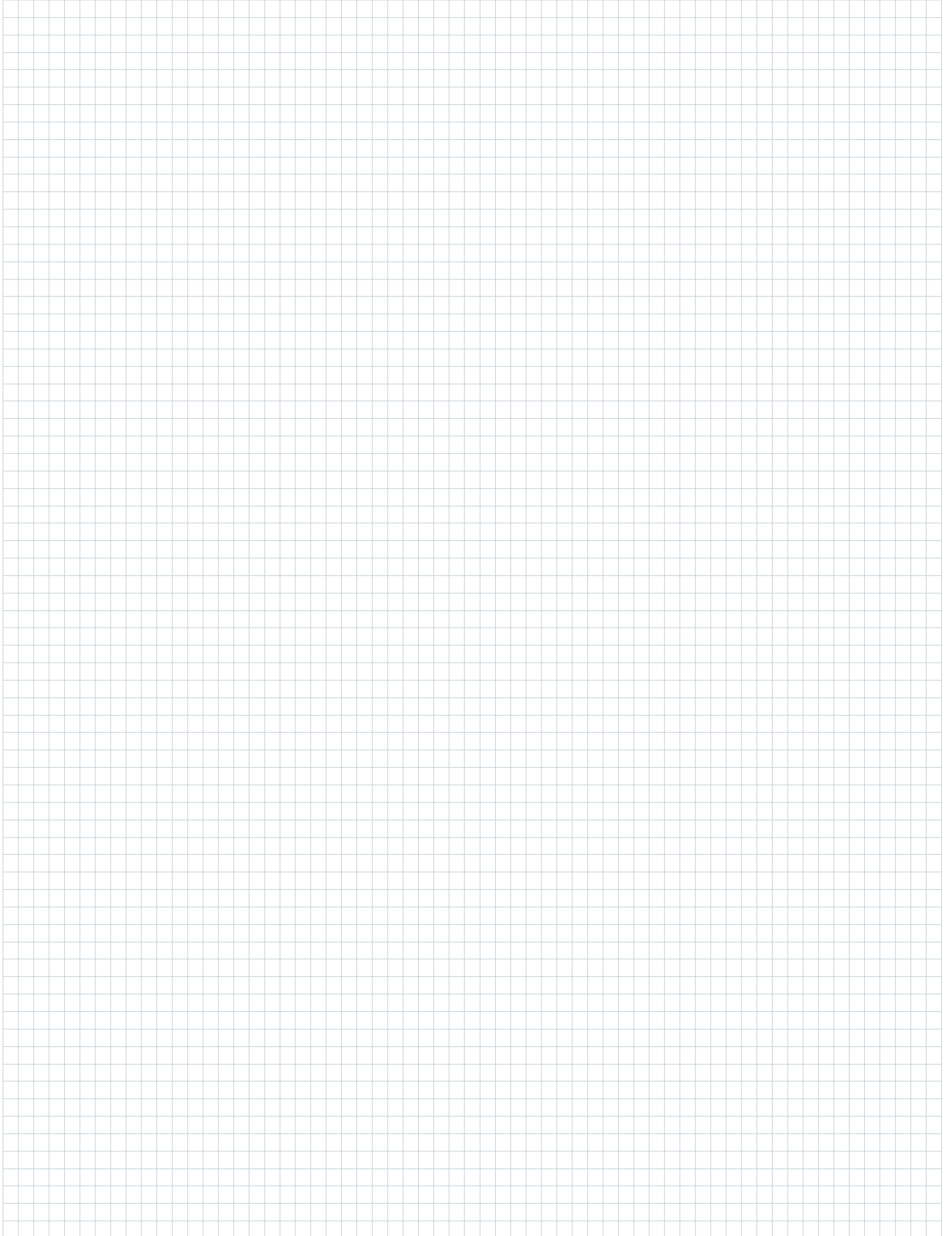

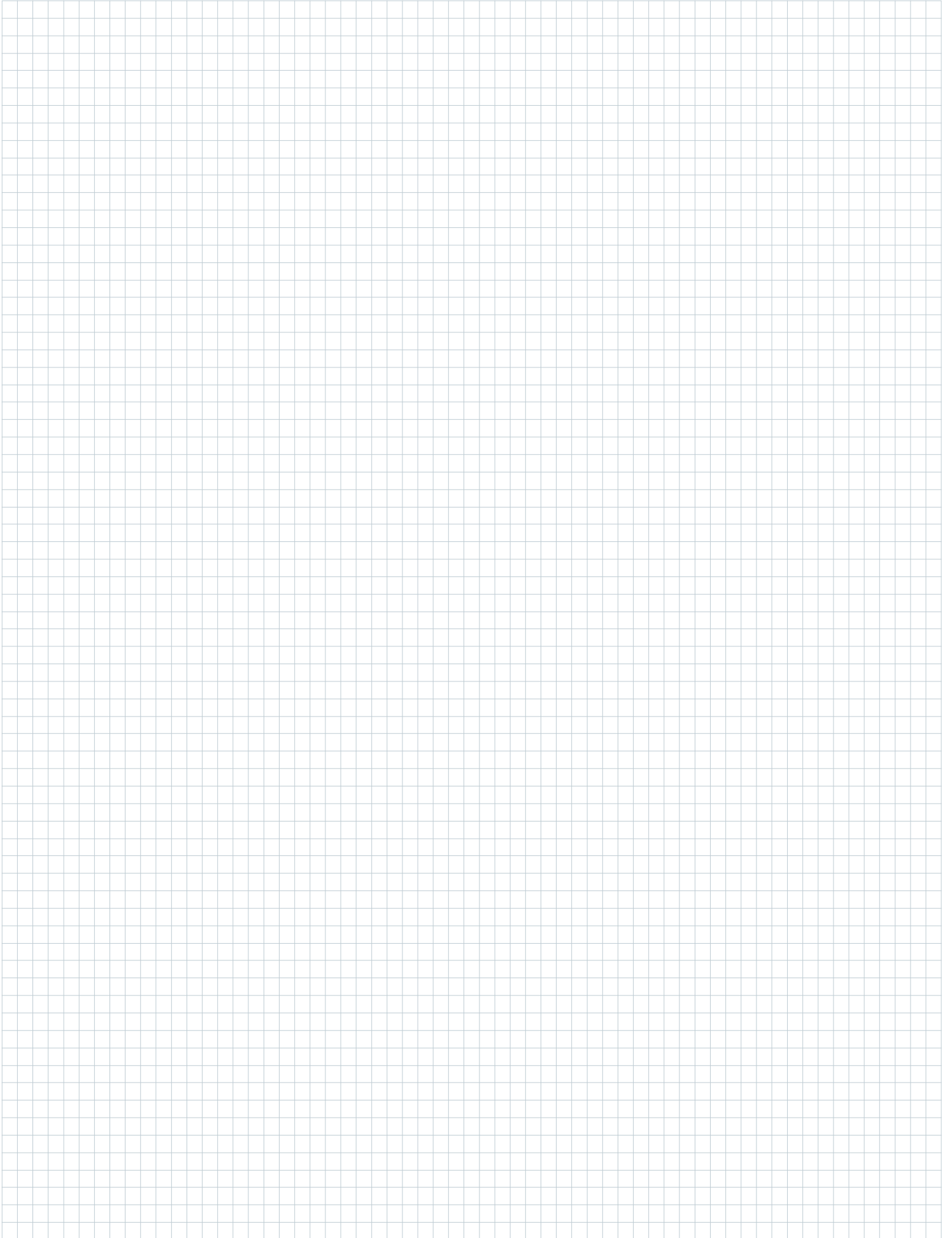

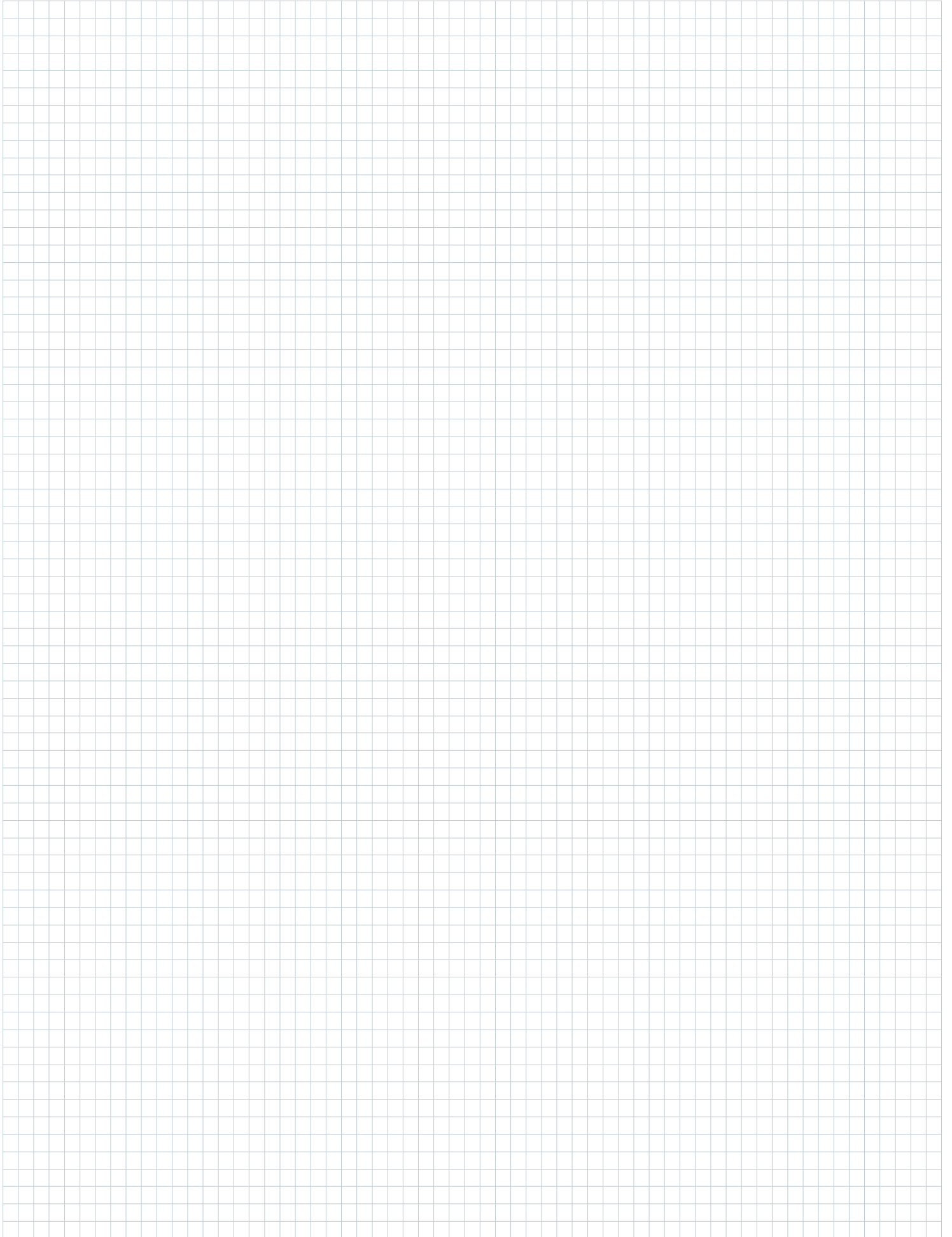



ISTANBUL

Address : Cevizli District, Zuhul Avenue, Fusun Street, Ritim Istanbul A5
Block Floor: 25 No: 137, 34846 Maltepe/Istanbul - TURKEY
Tel. : +90 216 455 29 60 / +90 216 455 29 61
Fax. : +90 216 455 29 62
E-mail : satis@eneko.com.tr

IZMIR

Address : 10049 Street No: 4 I.A.O.S.B. Cigli/Izmir - TURKEY
Tel. : +90 232 328 20 80
Fax. : +90 232 328 20 22
E-mail : info@eneko.com.tr
Web : www.eneko.com.tr

In parallel with our ongoing product development in R&D department, all rights of changing all technical specifications are reserved by ENEKO without any declaration and notice.

